



Humidifying air purifier

Floor Standing Type

Model

MCK55TVM6

Humidifying Air Purifier OPERATION MANUAL



- Thank you for purchasing this humidifying air purifier.
 - Please read the operation manual carefully and follow it for correct use.
 - **Please read the “Safety Precautions” section before use.** [▶Page 3, 4](#)
- Please keep the operation manual in a safe place for later reference.

English

Bahasa Indonesia

ภาษาไทย

Tiếng Việt

Features

Streamer Technology



STREAMER

This technology employs a "streamer discharge", a type of plasma discharge comprising high-speed electrons with powerful oxidative capacity, that is generated inside the air purifier. The discharge swiftly removes odours. (The high-speed electrons are generated and then adsorbed within the unit to ensure your safety.)

Streamer discharge decomposes adsorbed odour.

- Decomposition cycle that maintains deodorising capacity.

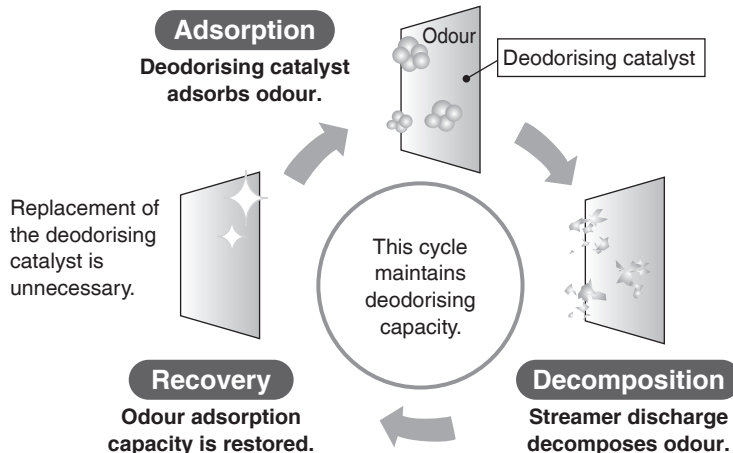

Streamer operation is conditional on the degree of air impurity.

During operation, the streamer discharge may generate a hissing sound, however, this does not indicate a defect.

In addition, the sound may lessen or change in tone depending on the operating environment, however, such changes are normal.

In some cases the air outlet may emit a slight odour as trace amounts of ozone are generated. However, the amount is negligible and is not harmful to your health.

Active plasma ion technology

• Deodorises curtains and other fabrics

Test methodology: Efficacy of deodorisation of cloth infused with tobacco aroma-compounds was evaluated on a 6-point odour intensity scale (conducted in approx. 10m² laboratory)

Test results: 1 point reduction in odour intensity after approx. 1 hour (research by Daikin)

- A 1 point reduction is a 90% decrease in odour.

- Efficacy of deodorisation depends on ambient conditions (temperature and humidity), operating time, odour levels, and fibre type.

• Increases skin moisture content

Evaluation method: Skin moisture content of 8 healthy women with sensitivity to skin dryness was measured in approx. 10m² room in the presence and absence of active plasma ion generation

Research body: National Institute of General Medical Sciences

Test number: MII-2010-10

Results: Skin moisture content increased 1.8 times over approx. 120 minutes

- Actual effects vary by operating environment and usage patterns.

Controlling PM2.5

These results were obtained in a 32m³ airtight space. They are not demonstrable effects in customer environments.

Elimination of 99% of 0.1-2.5µm particles (*1).

- Does not take into account inflow of new particles from outdoors owing to ventilation etc.
 - PM2.5 is a generic term for particulate matter that is 2.5µm or less in size.
 - Elimination of particulate matter that is less than 0.1µm in size by this humidifying air purifier has not been verified.
- This product cannot eliminate all airborne toxic substances.

(*1) Test methodology: The Japan Electrical Manufacturers' Association standard (JEM1467)

Decision criteria: Elimination of 99% of 0.1-2.5µm particulate matter in a 32m³ airtight space in 90 minutes or less.

Equivalent value for 32m³ test space.

Powerful and swift suction action driven by large airflow

Suction of house dust and odours with large airflow.

3 filter layer structure ensures thorough and rapid purification of the ambient air.

Substances that can be controlled/broken down

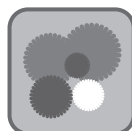

Mould



Pollen



Allergens such as dust mite droppings and remains



Odours



Formaldehyde



Diesel particulate matter



NOx

Substances that can be trapped



Dust



Yellow sand

Contents

Read First



Features	1
Safety Precautions	3
Precautions During Use	5
Names of Parts and Operations	6
Preparation Before Operation.....	10

Operation

Using the Air Purifying Operation	13
Changing the Airflow Rate	14
Using the Humidifying and Air Purifying Operation	14
Adjusting the Humidity	14

Useful Functions

Operating the Unit in a MODE	15
AUTO FAN / ECONO / ANTI-POLLEN / MOIST	
Using the Child Proof Lock	17
Adjusting Indicator Lamp Brightness	17

Advanced Settings

Streamer Output Settings	18
Active Plasma Ion Output Settings	18
Notification Tone Setting	19
Setting Dust/PM2.5 Sensor Sensitivity	19
Settings of Modes within ECONO MODE	20

Maintenance



Maintenance Quick Reference Table	21
Humidifying Tray / Humidifying Filter Unit	23
Replacing the Humidifying Filters	25
Replacing the Dust Collection Filter	26
Separately Sold Parts / When Not Using the Unit for Long Time Periods ...	27

Troubleshooting

About the Indicator Lamps	28
FAQs	29
Troubleshooting	30
Specifications	i

Safety Precautions

- Observe these precautions in order to prevent property damage or injury.
- The consequences of incorrect use are categorised as follows.



 WARNING	 CAUTION
Failure to follow these instructions properly may result in personal injury or loss of life.	Failure to follow these instructions properly may result in property damage or personal injury, which may be serious depending on the circumstances.

- Precautions to be observed are categorised using symbols.

 Never attempt.	 Be sure to follow the instructions.
--	---

WARNING Observe in order to prevent fires, electric shocks or severe injury.

■ Concerning the power supply plug and cord

-  Do not unplug while the unit is in operation. (Fire or an electric shock may result from heating)
-  Do not plug or unplug with wet hands. (An electric shock may result)
- Do not use in such a way that the ratings of the power socket or wiring appliances are exceeded or use a voltage outside of the range AC220-240V.
(Fire may result from heating if the ratings of multi-socket power adapters, etc., are exceeded)
- Do not pull on the power supply cord when unplugging. (Heating or fire may result from wire breakage)
- Do not subject to acts that might damage them.
– Such acts include damaging, modifying, forcibly bending, pulling, twisting, bundling up, placing heavy objects on, etc., the power supply plug or cord. If the power supply plug or cord is damaged, it must be replaced by the manufacturer, its service agent, or a similar qualified person in order to avoid a hazard.
(An electric shock, short circuiting, or fire may result from use while damaged)
-  Insert the power supply plug firmly all the way in.
– Do not use a damaged power supply plug or a loosely fitted power socket.
(An electric shock or fire, due to heating or short circuiting, may result if the power supply plug is not firmly inserted)
- Periodically wipe dust off the power supply plug with a dry cloth.
– If the unit is not to be used for an extended period of time, unplug the power supply plug.
(Fire or overheating may be caused by defective insulation resulting from moisture etc.)
- When performing maintenance, inspecting, moving the unit, or refilling the water tank, make sure to turn off and unplug the appliance. (An electric shock or injury could result)

■ Do not use in the following places

-  Places where oil or flammable gases are used or may leak. (Fire or smoke may result from ignition or suction toward the unit, or injury may result from degradation or cracking of plastic)
- Places where there is corrosive gas or metal dust particles.
(Fire or smoke may result from ignition or suction toward the unit)
- Places where temperature and humidity levels are high or water may scatter, such as a bathroom. (Fire or an electric shock may result from electrical leakage)
- Places accessible to small children. (An electric shock or injury may result)
- Places where the floor is unstable.
(Household items etc., may get wet, or a fire or an electric shock may result if the unit topples over)

■ During use

-  Do not use chlorinated or acidic detergents. (Injury may result from the degradation or cracking of plastic, or harm may be caused to health from the production of toxic gases)
- Keep burning cigarettes or incense sticks away from the unit.
(Fire or smoke may result from ignition or suction toward the unit)
- Do not attempt to disassemble, reconstruct or repair the unit yourself.
(Fire, an electric shock, or injury may result) For repairs, please contact the place of purchase.
- Do not insert fingers, sticks, or any other item, into the air inlets or air outlet.
(An electric shock, injury, or damage may result)
- Do not pour water on to the air outlet or the unit. (Fire or an electric shock may result)
- Do not use flammable substances (hair spray, insecticide, etc.) near the unit.
Do not wipe the unit with benzine or thinner. (An electric shock, fire, or cracking may result)

⚠ WARNING Observe in order to prevent fires, electric shocks or severe injury.

■ **Concerning the remote controller**

- ⊘ **Do not place the remote controller in places where small children can reach.**
(Bodily harm may result from misoperation of the unit or accidental ingestion of the batteries)
- **Make sure not to insert the batteries in the wrong polarity (+/-) orientation.**
(Short circuiting, fire, or battery leakage may result)

■ **Immediately turn off and unplug the unit if there are any signs of abnormality or damage**

⚠ Examples of abnormality or damage

- The unit does not operate even if the switch is turned on.
- Current passes through the cord only sometimes if the cord is moved.
- There are abnormal sounds or vibrations during operation.
- The casing of the unit has deformed or is abnormally hot.
- There is a burnt smell. (Malfunctioning, an electric shock, smoke, fire, etc., may result if the abnormality is not addressed and the unit continues to be used)

Contact the place of purchase.

⚠ CAUTION Observe in order to prevent short circuiting, injury or property damage.

■ **During use**

- ⊘ **Small children or immobile persons (due to illness or injury) should not operate the unit by themselves.**
This appliance is not intended for use by persons (including children) with reduced physical, sensory or mental capabilities, or lack of experience and knowledge, unless they have been given supervision or instruction concerning use of the appliance by a person responsible for their safety.
 - Children should be supervised to ensure that they do not play with the appliance.
 - Persons who are heavily intoxicated or have taken sleep medication should not operate the unit.
(An electric shock, injury or poor health may result)
- **Do not drink the water in the water tank. Do not give the water to animals or plants.**
(Harm may be caused to the animal or plant)
- **Do not use products, such as cosmetics, that contain fine powder, near the unit.**
(An electric shock or malfunctioning may result)
- **Do not operate the unit when fumigating insecticide is in use.**
 - After using insecticide, make sure to sufficiently ventilate the room before operating the unit.
(Harm may be caused to health from an outflow of accumulated chemical compounds from the outlet)
- **Do not use near a smoke detector.**
 - If out flowing air flows in the direction of a smoke detector, the response of the smoke detector may be delayed or it may fail to detect smoke.

- ⚠ **Frequently ventilate the room when using the unit together with combustion-based heating devices.**
 - Usage of this product is not a substitute for ventilation. (Potential cause of carbon monoxide poisoning)
This product cannot eliminate carbon monoxide.
- **If the unit is placed within reach of a pet, be careful that the pet does not urinate on the unit or chew on the power supply cord.** (Fire, an electric shock, or injury may result)
- **When using the humidifier, keep the water tank, humidifying tray, and humidifying filter unit clean at all times.**
 - Replace the water in the water tank with fresh tap water everyday.
 - Discard any water remaining in the humidifying tray everyday.
 - Periodically perform maintenance on internal components (humidifying tray, humidifying filter unit).
(Harm may be caused to health from the propagation of micro-organisms in stains and water scales)
Consult a medical professional if you experience any health abnormalities.

■ **Concerning the unit body**

- ⊘ **Do not obstruct the air inlets or air outlet with laundry, cloth, curtains, etc.**
(Overheating or fire may result from poor circulation)
- **Do not climb, sit or lean on the unit.** (Injury may result from falling or toppling)
- **Do not place the unit on its side.** (An electric shock or malfunction may result from water leaking or spilling)

■ **When moving the unit**

- ⚠ **Before moving the unit, turn off the power, and discard any water in the water tank and humidifying tray.**
(Household items etc., may get wet, or an electric shock or electrical leakage may result from water leaking or spilling)
- **When picking up the unit to move it, handle the unit with caution.**
 - Make sure to always hold the unit using the correct grips. Do not hold the unit using the grip on the water tank or humidifying tray. (Injury may result from falling)

Precautions During Use

Other considerations

- **Do not use this product for special purposes such as in the preservation of works of art, academic texts/materials, etc.**
(Degradation of preserved items may result)
- **Do not excessively humidify the air.**
(Condensation and mould growth may result)
- **Be careful of freezing.**
(Malfunctioning may result)
Discard any water in the water tank and humidifying tray if there is any risk of freezing.
- **When not using the Humidifying operation, discard any water in the water tank and humidifying tray.**
(Bad odours may result from the propagation of micro-organisms in stains and water scales)

Do not use in the following places

- **Positions from where out flowing air flows directly at a wall, furniture, curtains, etc.**
(Staining or deformation may result)
- **On top of a thick carpet, bed cover, or mattress**
The unit may tilt causing water to spill or the water level sensor may fail to work correctly.
- **Places exposed to direct sunlight**
(Decline in the receptivity of the remote controller signal receiver or discolouration may result)
- **Places exposed to outdoor air (e.g. near windows, etc.) or direct airflow from air conditioners, etc.**
Room humidity may not be detected and indicated correctly.
- **Positions near combustion-based heating devices or exposed to direct airflow from heating appliances**
(Room humidity may not be detected and indicated correctly or deformation may result)
- **Places where chemicals and pharmaceuticals are used such as hospitals, factories, laboratories, beauty salons, and photographic laboratories**
(Volatilised chemicals and solvents may degrade mechanical parts, cause water leaks and get household items etc., wet)
- **Places with high levels of electromagnetic waves such as near an electromagnetic cooker, speakers, etc.**
The unit may not function correctly.
- **Places exposed to soot (conductive dust) released by candles, aromatic candles, etc.**
The performance of the filters may be impaired, causing the room to become dirty due to the build-up of dust that is not captured.
- **Do not use cosmetics etc., containing silicone* near the unit.**
* Hair care products (split ends coating agents, hair mousse, hair treatment agents etc.), cosmetics, antiperspirants, antistatic agents, waterproof sprays, lustering agents, glass cleaners, chemical wiping cloths, wax, etc.
 - If an insulator such as silicone adheres to the needle of the streamer unit, the streamer discharge may not be generated.
 - The dust collection filter may become clogged up resulting in reduced air purifying capacity.
- **Do not use an ultrasonic humidifier or similar appliance near the unit.**
The dust collection filter may become clogged up resulting in reduced air purifying capacity.

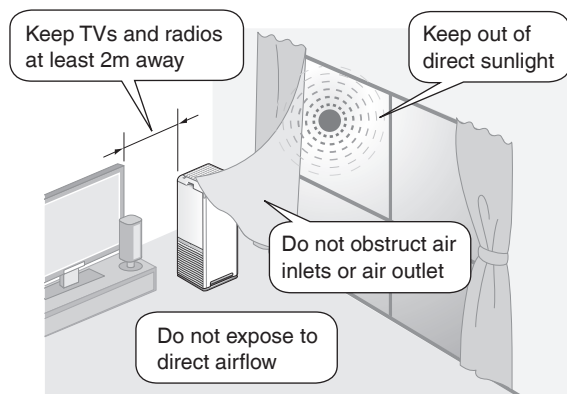

About streamer discharge and active plasma ions

In some cases the air outlet may emit a slight odour as trace amounts of ozone are generated. However, the amount is negligible and is not harmful to your health.

This product cannot eliminate the toxic substances in tobacco smoke (carbon monoxide etc.)

Names of Parts and Operations

⚠ CAUTION

Do not lift up the unit holding the grip on the water tank or humidifying tray. (May lead to falling over)

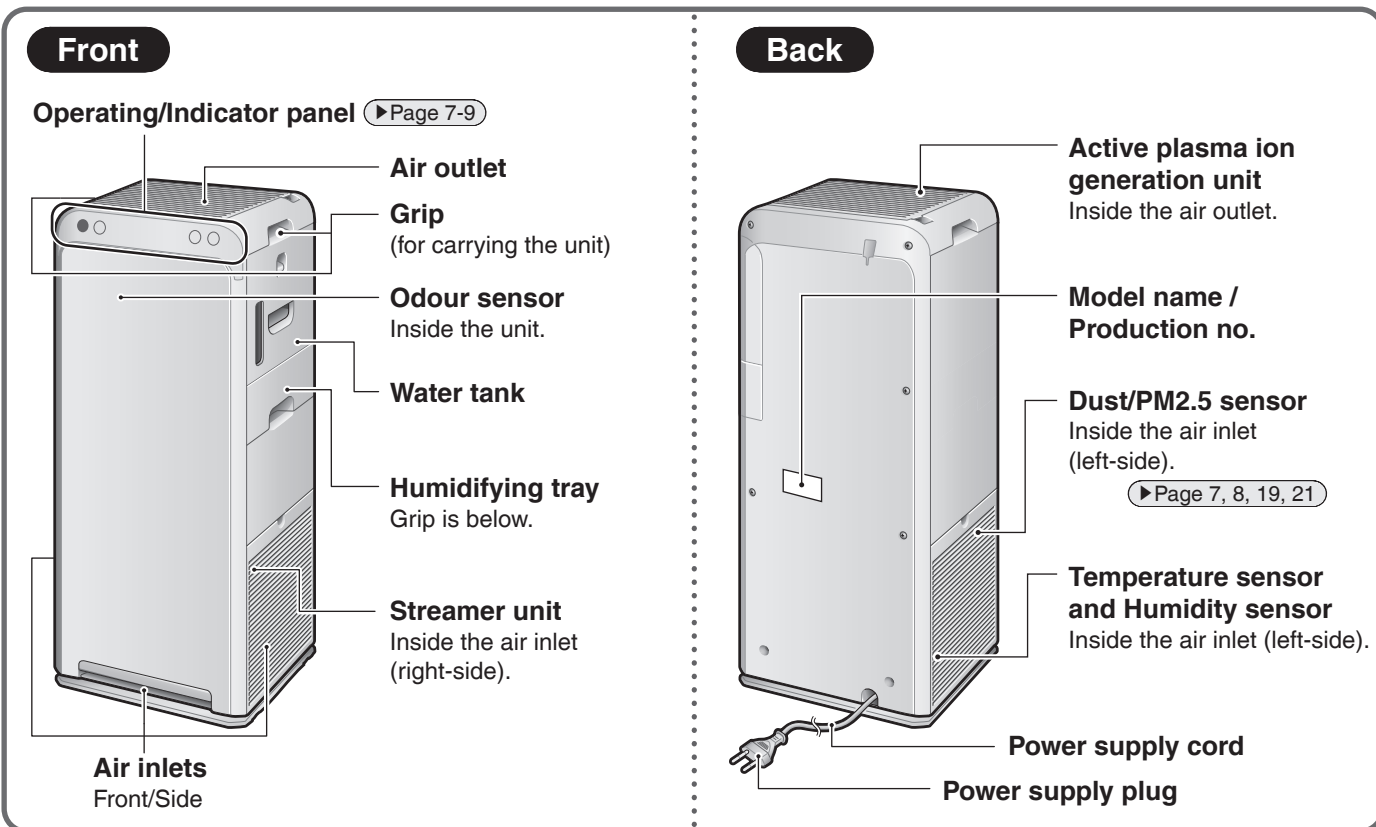

Main Removable Parts

Attention

To prevent malfunctioning, make sure to only operate the unit with all parts attached.

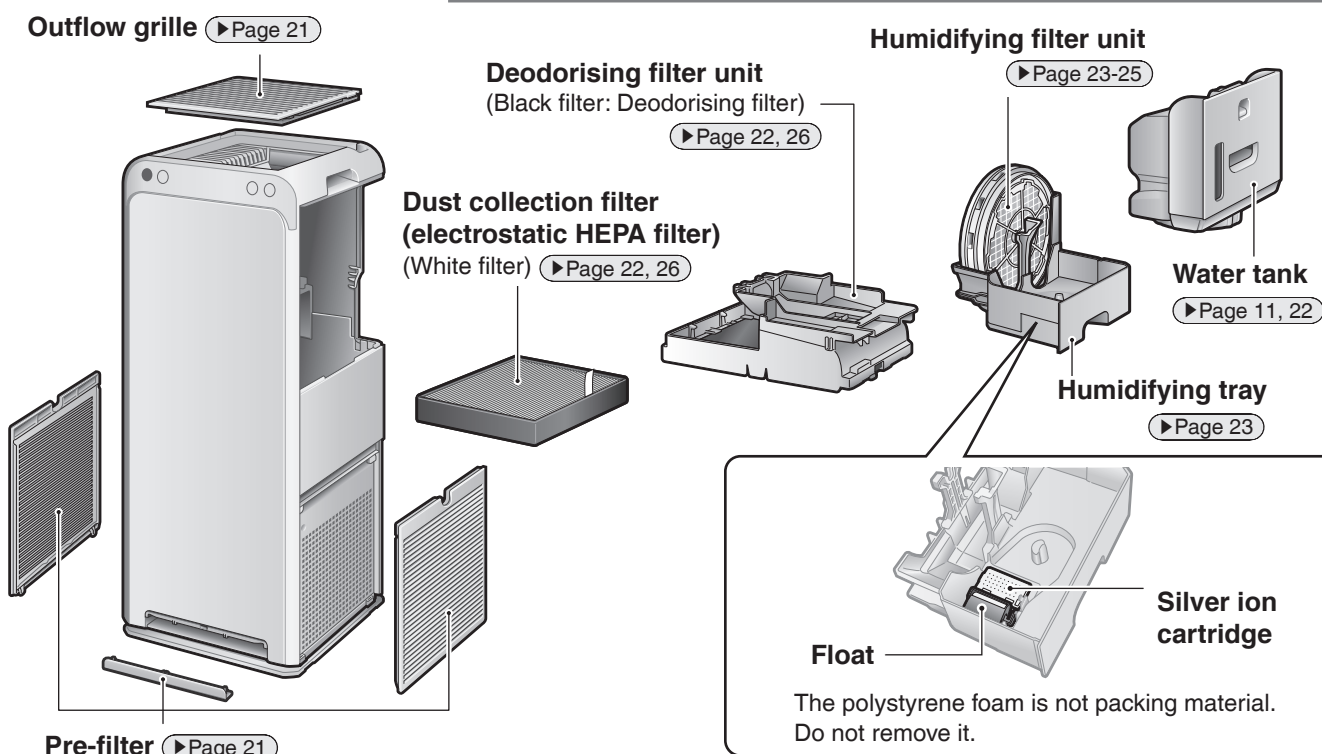

Names of Parts and Operations

Operating/Indicator panel

When a lamp is blinking [▶Page 28](#)

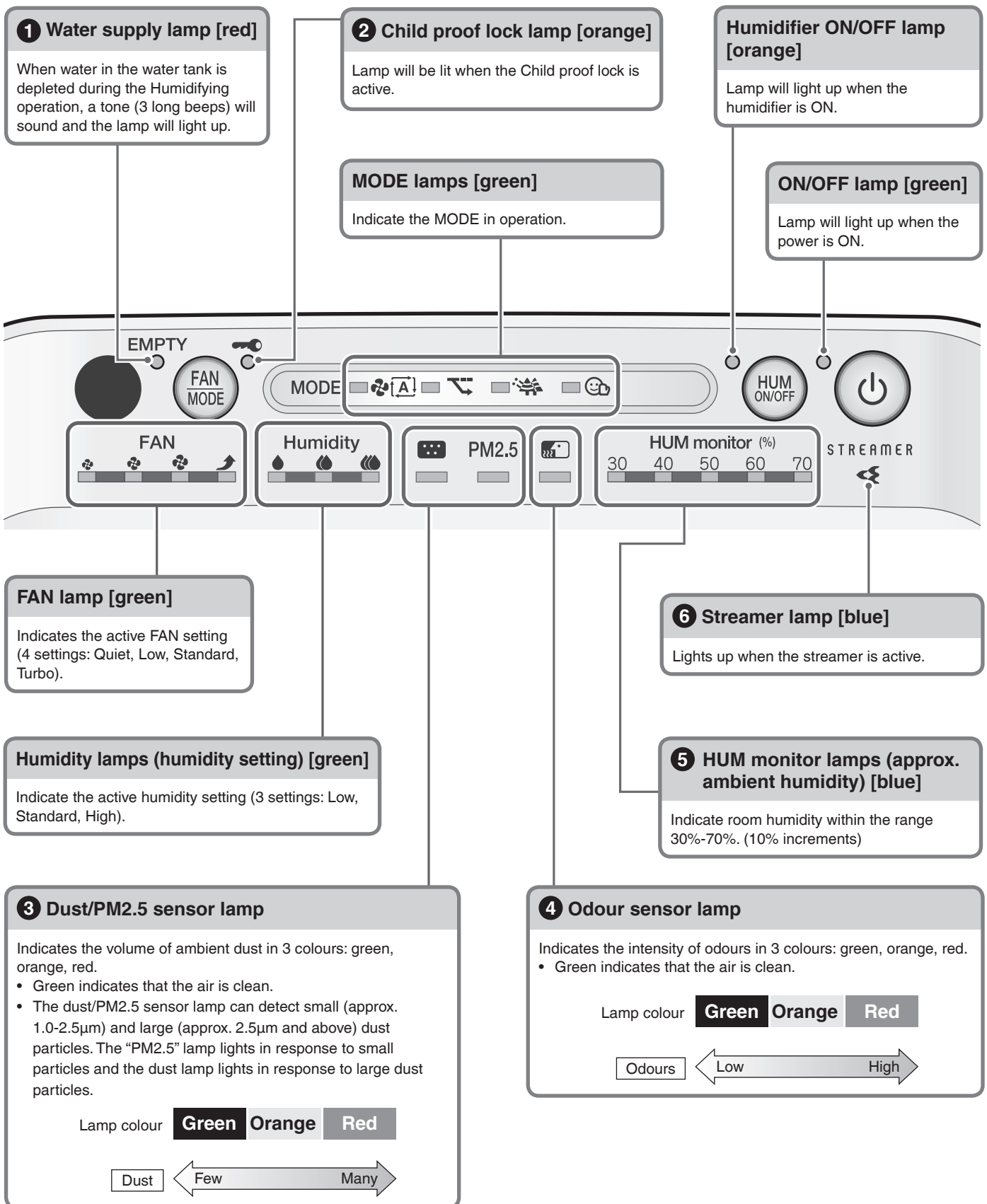

About the lamps

1 About the water supply lamp

- After the water supply lamp lights up, the Humidifying operation will stop (the Air purifying operation will continue) but the humidifier ON/OFF lamp will remain lit up.
- After lighting up, the water supply lamp may light on and off a few times, however, this is normal (not a malfunction).
- The water supply lamp will light off and the **Humidifying operation** will recommence after the water tank is filled with water and re-inserted into the unit. [▶Page 11](#)
- To stop the notification tone (3 long beeps) sounding, change the settings. [▶Page 19](#)

2 About the child proof lock lamp

- When lit up, operations will be restricted. When buttons are pressed, only a tone (3 short beeps) will sound, preventing misoperation by small children. [▶Page 17](#)

3 About the dust/PM2.5 sensor lamp

- **After operation is started, the lamp will light green for the first minute (approx.) regardless of air impurity level.**
- If the responsiveness of the dust/PM2.5 sensor is poor, change the sensitivity setting of the sensor. [▶Page 19](#)
- The responsiveness of the dust/PM2.5 sensor may be poor during FAN setting “Turbo” or when airflow is high in AUTO FAN MODE or MOIST MODE. The strong airflow causes dust to be drawn into the air inlets before it can be detected by the dust/PM2.5 sensor. This is normal (not a malfunction).

Dust/PM2.5 sensor detection range

Detectable matter
house dust, tobacco smoke, pollen, mites, pet hairs, diesel particulate matter
Sometimes detectable
steam, oil smoke

4 About the odour sensor lamp

- **If operation is started immediately after the power supply plug is inserted, the lamp will light green for the first minute (approx.)**
- If odour intensity levels are unchanging, the sensor may not respond even if there is a strong odour in the air.
- The sensor may not respond to some odours such as pet odours excluding ammonia, garlic odour, etc.
- As odour perception varies by person, in some cases an odour may be sensed even when the lamp is green.
If the odour bothers you, switch to manual airflow rate, and select a high airflow rate. [▶Page 14](#)

Odour sensor detection range

Detectable matter
tobacco odours, cooking odours, pet odours, toilet smells, waste smells, mould odour, sprays, alcohol
Sometimes detectable
sudden changes in temperature/humidity, steam, oil smoke, gas emitted from combustion-based heating devices

The ambient odour level in the first minute after the unit is plugged in serves as the reference level upon which the sensitivity of the odour sensor is determined. Insert the power supply plug when the air is clean (odour-free).

5 About the HUM monitor lamps

- When the humidity level is below 30%, the “30” lamp will light up. When the humidity level is above 70%, the “70” lamp will light up.
- Light up even when only the Air purifying operation is active.

At times the humidity level indicated on the unit may differ from other hygrometers.







- This is because the flow of air causes temperature and humidity to vary throughout the room. Please consider the indications to be a rough estimate of ambient humidity.

6 About the streamer lamp

- During streamer operation, this lamp lights up. Streamer operation is conditional on the degree of air impurity.
- If the hissing sound generated by the streamer discharge or the smell of ozone bother you, set streamer output to low. [▶Page 18](#)

About the FAN and Humidity symbols

Symbol table *The size of the symbols varies in accordance with the airflow rate setting.

	FAN				Humidity		
Symbol							
Setting	Quiet	Low	Standard	Turbo	Low	Standard	High

Names of Parts and Operations

Operating/Indicator panel

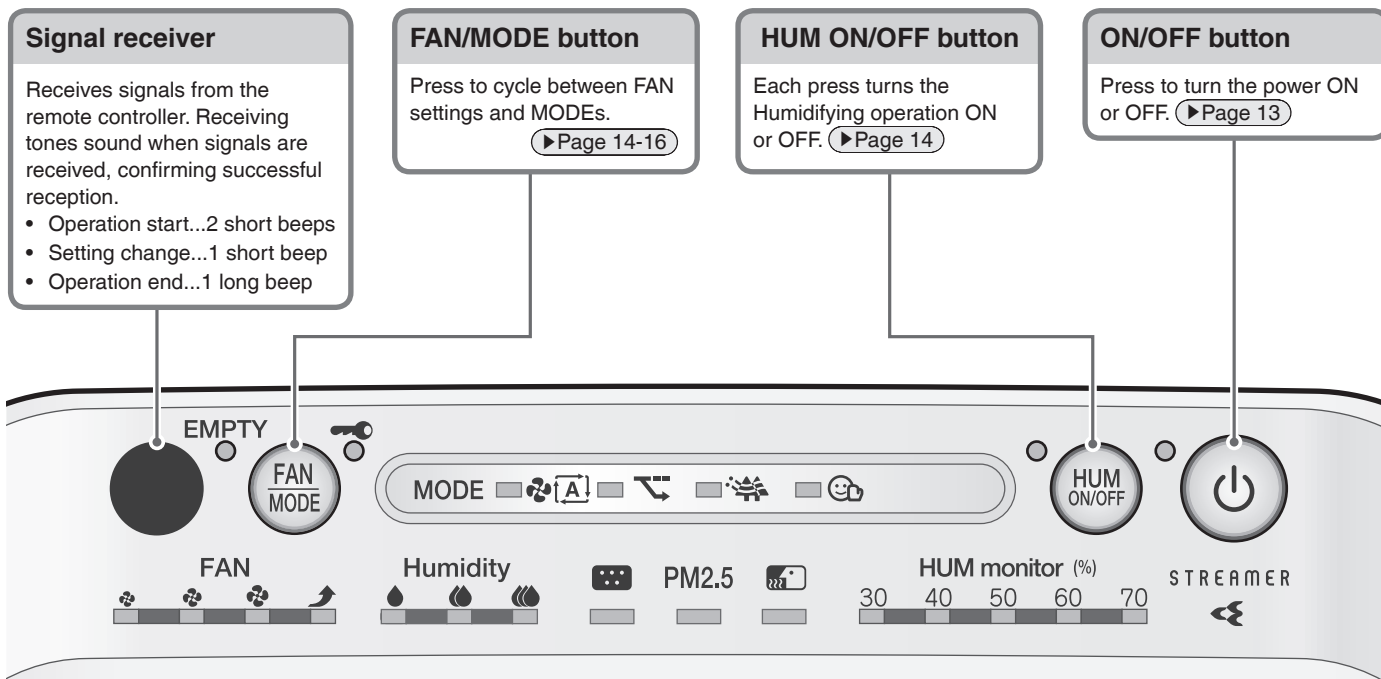

Remote controller

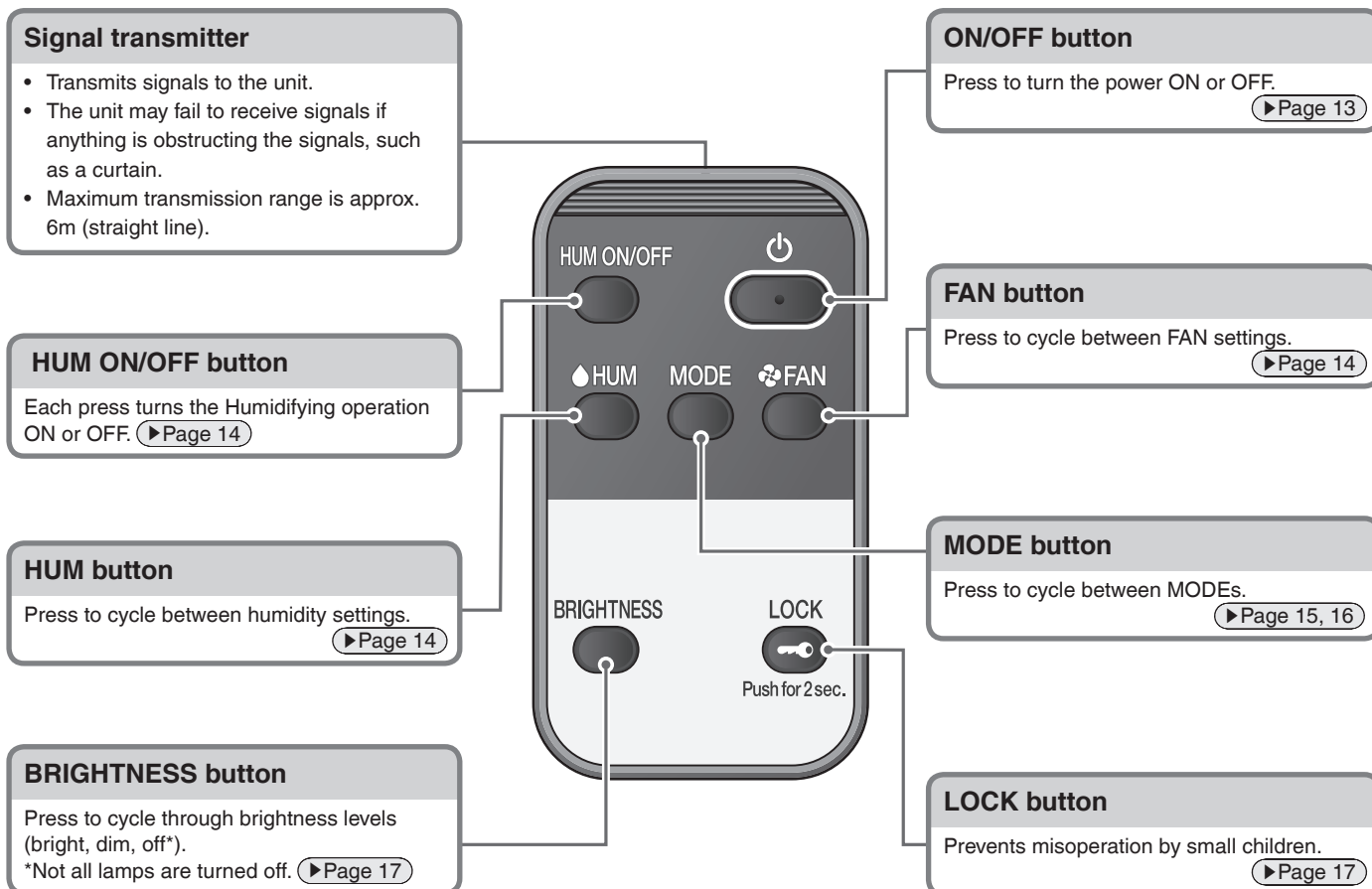

Preparation Before Operation

1 Accessories check



Operation manual 1

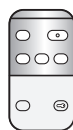

Remote controller 1



Remote controller holder 1

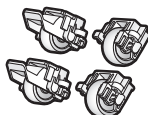

Caster 4

2 Attaching the casters

1. Place down the unit so that the front of the unit faces upward.
 - The front may be scratched if faced downward.
2. Tighten securely using the included screws to prevent rattling.

Attachment orientation

- Attach the casters with lock to the corners at the front of the unit.

Casters with lock

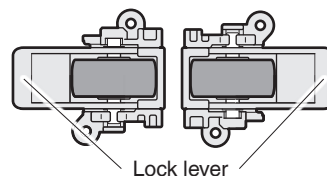

Casters without lock

Attach so that this side faces toward the front of the unit.

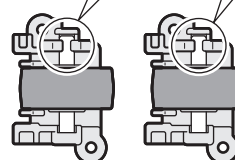

(Viewed from below)

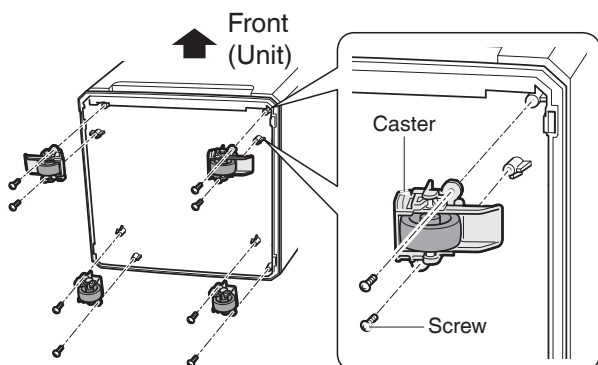

Attention

- Do not use the lock levers while attaching the casters, as it may cause the wheels to detach.
- When moving the unit with the casters, make sure to move it slowly as floor surfaces may be scratched depending on the flooring material.

How to use

- There are 2 lock levers at left and right side.

Lock

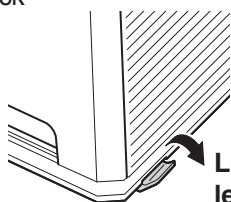

Lower the lock lever to lock

Unlock

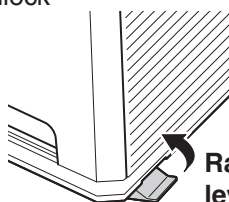

Raise the lock lever to unlock

Attention

Please use your hands to operate the lock levers.

Preparation Before Operation

3 Positioning the unit

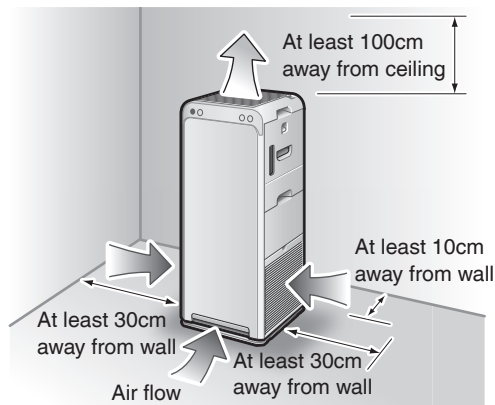

Pointers for good positioning

- Choose a position from where airflow can reach all areas of the room.
- Place on a stable surface. If the unit is placed on an unstable surface, vibrations from the unit may be amplified.
- If you find that interference from the power circuit inside the unit or cables causes interference on your TV screen or static noise to be emitted from nearby radios or stereos, move the unit to at least 2m away from the device. Keep cordless phones and radio-controlled clocks away from the unit also.

Attention

- To avoid staining of walls, position the unit in accordance with the positioning measurements in the illustration. However, note that since this unit draws in dirty air, certain types of wall may be stained even if the measurements are adhered to. In such cases, make sure to maintain sufficient distance between the unit and the wall.
- When used for a long period of time in the same location, the floor and surrounding walls may get stained as air is drawn into air inlets near the base of the unit. It is recommended to clean the unit periodically.

4 Preparing the water tank (for Humidifying operation)

1. Take out the water tank and remove the cap.

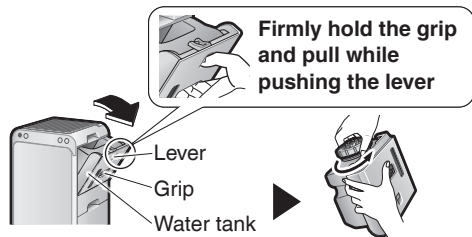

- The water tank will be heavy when filled with water. Hold the water tank firmly when carrying.
- Avoid touching the valve in the centre of the cap. Water in the water tank will leak.
- Check for any leaks.



2. Fill the water tank with tap water and close the cap.

Attention

- Do not pour any of the following into the water tank.
- Warm water (40°C or above), aroma oil, chemical agents, unclean water, aromatic substances, detergent, etc. These may cause deformation of the unit or malfunctioning.
 - Water from a water purifier, ionised alkaline water, mineral water, well-water etc. These may lead to the propagation of mould and bacteria.

- Perform in a place that is okay to get wet.
- Clean the water tank by shaking a small amount of water inside before filling up the water tank with water.
- For maintenance procedures refer to [▶Page 22](#).



Securely tighten the cap on the water tank. Water leakage could result.

3. Re-attach the water tank.

- Hold the grip and fit the water tank into the humidifying tray.

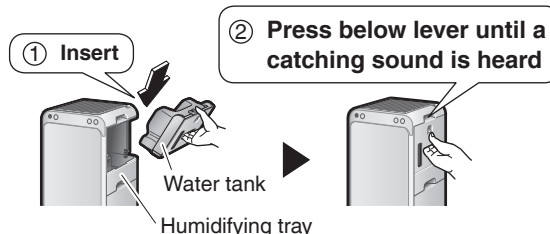

Attention

Leaving any residual water in the humidifying tray will lead to bad odours and dirt build-up. Therefore, make sure to discard any residual water in the humidifying tray each time you refill the water tank. If there is a bad odour or dirt, refer to [▶Page 23](#).

5 Preparing the remote controller

1. Attach the remote controller holder.

- Insert the hook on the remote controller holder into the notch in the back of the unit.

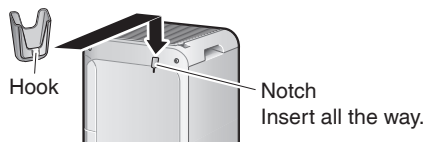

2. Pull out the transparent sheet.

- After removing the transparent sheet, the remote controller is ready for use.

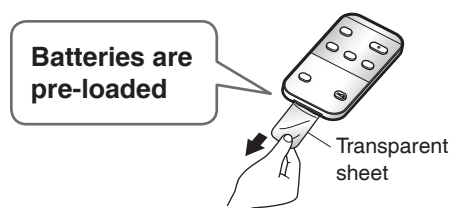

How to use

- Direct the signal transmitter on the remote controller at the signal receiver on the unit. The unit may fail to receive signals if anything is obstructing the signals, such as a curtain.
- Maximum transmission range is approx. 6m (straight line).

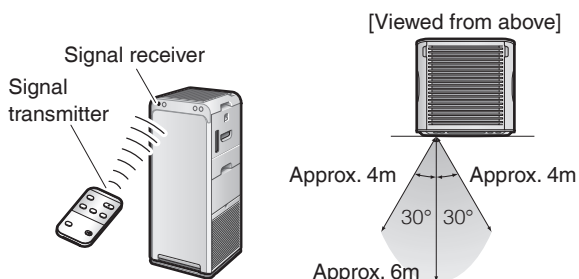

About the remote controller

- Make sure not to drop or allow water to get into the remote controller. (Malfunction may result)
- Signal reception may be poor in rooms with electronic-starter-type fluorescent lamps (inverter-type fluorescent lamps etc.).
- Do not use near lighting equipment (within 1m). (Decline in the receptivity of the remote controller signal receiver or discolouration may result)

Replacing the battery

1. Move the catch on the cover at the bottom of the remote controller in the direction of the arrow.
2. Pull out the cover.
3. Replace the battery.
4. Return the cover to its original position.

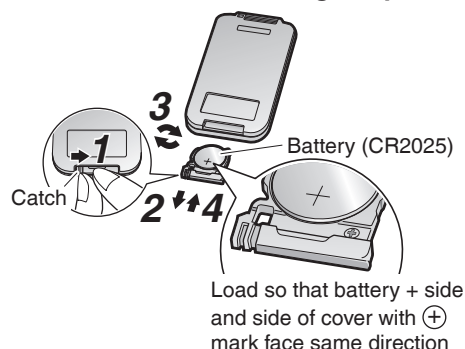

About the battery

- Keep batteries out of reach of children. In the event that batteries are swallowed, seek the immediate attention of a medical professional.
- To avoid possible injury or damage from battery leakage or rupturing, remove the battery when not using the product for long periods of time.
- If the alkaline solution from batteries should get in the eyes, do not rub the eyes. Instead, immediately flush the eyes with tap water and seek the attention of a medical professional.
- Do not expose batteries to heat or fire. Do not disassemble or modify batteries. The insulation or gas release vent inside the battery may be damaged, resulting in battery leakage, rupturing, or heating.
- When disposing of the battery insulate the terminal by wrapping it in tape etc. (Heating, rupturing, or fire may result if stored together with other metal objects or batteries) Observe local waste separation rules when disposing of button batteries.
- As a guideline, you should replace the battery once a year. However, the battery should be replaced with a new battery (CR2025) when signal reception weakens.
- Batteries with an expiration date that is close, may require replacement sooner.
- The pre-loaded battery is for initial use of the unit. It may require replacement after less than 1 year.

6 Insert the power supply plug into the socket

- The sensitivity of the odour sensor will be determined by odour levels in the first minute (approx.) after the power supply plug is inserted. **Insert the power supply plug when the air is clean (odour-free).**

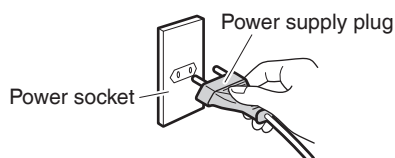

Do not turn off the unit by unplugging it from the power socket. (Fire or an electric shock may result from heating)

Operation

Operation

Detailed settings can be made using the remote controller.

Remote controller

Operation via remote controller.

Unit

Operation via operating/indicator panel on unit.

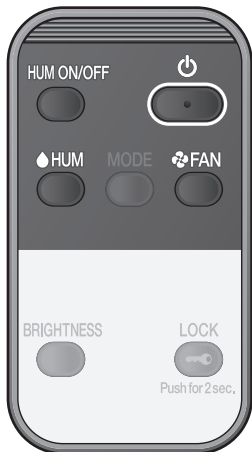

Attention

- Do not move the unit, or attach or remove parts to/from the unit while it is in operation. Water leakage, breakage or malfunctioning may result.

Using the Air Purifying Operation (turning operation ON/OFF)

Cleans the air in the room.

Remote controller

Press  .

Unit

Press  .

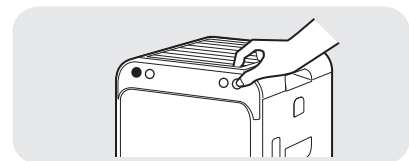

- ON/OFF lamp [green] lights up.
- Press again to turn OFF.
- If the Humidifying operation was running previously, the Humidifying operation will start automatically the next time the unit is turned ON.

To use the Air purifying operation only, turn OFF the humidifier by pressing  or  .

Attention

When using the Air purifying operation only, discard any water in the water tank and humidifying tray.

Note

- At the time of purchase, the unit is set to Air purifying operation, AUTO FAN MODE with active plasma ion generation set to ON.
- When the unit is unplugged or turned OFF, it will operate with the settings last used the next time it is turned ON.
- Operation settings cannot be changed for about 2 seconds immediately after the power supply plug is inserted.

Changing the Airflow Rate

Select the desired FAN setting.

: Quiet
 : Low
 : Standard
 : Turbo
 * The size of the symbols varies in accordance with the FAN setting.

Remote controller

Press .

- Each press cycles between the FAN lamps [green].



Unit

Press .

- Each press cycles between the FAN lamps [green] and MODE lamps [green].

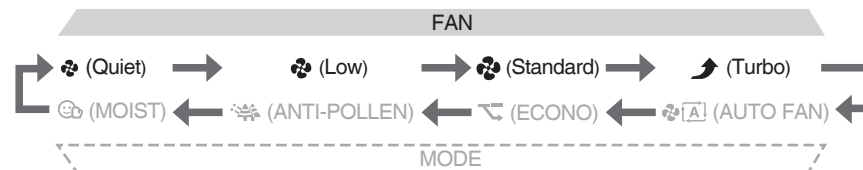

About FAN settings

Quiet

A gentle breeze is emitted. Recommended for use during sleep hours. To quickly eliminate odour from a room, it is recommended that the FAN setting be set to Standard or above otherwise deodorising capacity is reduced.

Turbo

The ambient air is quickly purified using a large airflow. Recommended for use while you are cleaning up a room.

Using the Humidifying and Air Purifying Operation

Humidifies and cleans the air in the room.

Fill the water tank with water. [▶Page 11](#)

Remote controller

Press .

- Same to cancel the operation.
- The Humidifier ON/OFF lamp [orange] lights up.

Unit

Press .

Attention

Make sure that the humidifying filter unit is attached when using this operation. Change the water in the humidifying tray and water tank everyday.

Air purification is always performed with humidification. (It is not possible to run the Humidifying operation exclusively.)

Note

- Indoor temperature may fall when the Humidifying operation is running.
- Bubbling or splashing sounds may be heard when the Humidifying operation is running, however, this is normal (not a malfunction).
- When the target humidity level is reached or the water supply lamp lights up, the Humidifying operation stops. However, the Air purifying operation continues.
- If or is pressed when MOIST MODE is active, the Humidifying operation stops and AUTO FAN MODE is activated.

Adjusting the Humidity

Select the desired humidity level.

Remote controller

Press .

- Each press cycles between the Humidity lamps [green].



Unit

Cannot be set from unit.

About humidity settings

- Low Targets a humidity level of around 40%*.
- Standard Targets a humidity level of around 50%*.
- High Targets a humidity level of around 60%*.

* Depending on room conditions such as indoor and outdoor temperatures and humidity levels, the target humidity level may be exceeded (or not reached). [▶Page 33](#)

Note

- If is pressed when the Humidifying operation is OFF, the Humidifying operation turns ON.
- Humidity level cannot be selected when MOIST MODE is active. If is pressed when MOIST MODE is active, MOIST MODE stops and AUTO FAN MODE is activated. Humidity level will be the level selected previously.

Useful Functions

Remote controller



Unit

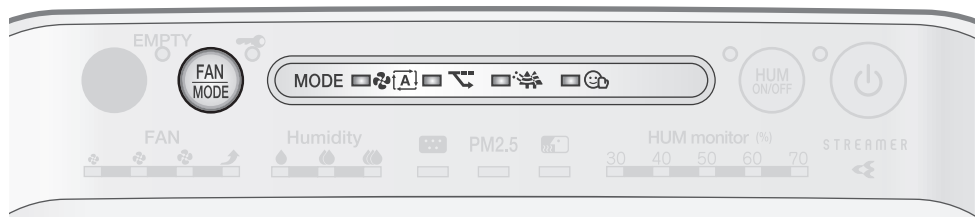

Operating the Unit in a MODE

Select a MODE specific to your needs.
Airflow is adjusted automatically when the unit is running in a MODE.

Remote controller

Press .

- Each press cycles between the MODE lamps [green].



Unit





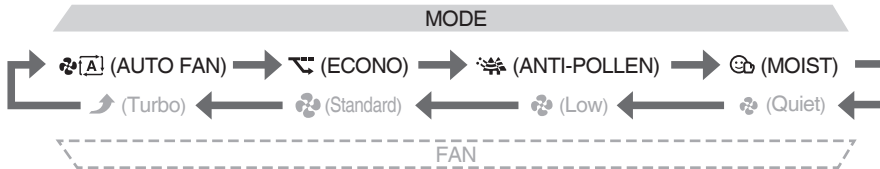

Press .

- Each press cycles between the MODE lamps [green] and FAN lamps [green].



Note

- **The humidifier is turned ON when MOIST MODE is selected.**
- If FAN setting (Quiet) or AUTO FAN MODE is selected after the unit has been running in MOIST MODE for a while, the Humidifying operation will continue.
(The Humidity level will be the level selected before MOIST MODE was activated.)

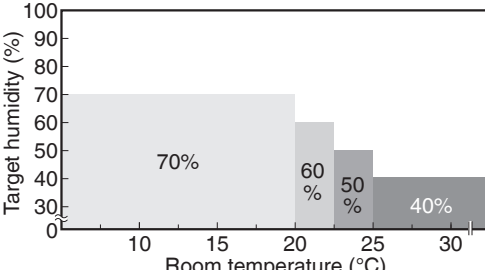
MODE	Usage and Function										
<p>AUTO FAN</p>	<p>Automatic airflow rate adjustment</p> <p>FAN setting (Quiet, Low, Standard, High) is automatically adjusted according to the degree of air impurity and humidity (when the Humidifying operation is active). Purifying capacity increases as airflow rate rises.</p> <ul style="list-style-type: none"> Press  to select the humidity level. Degree of air impurity corresponds to the volume of dust and the intensity of odours in the ambient air. 										
<p>ECONO</p>	<p>Saving energy</p> <p>In Power saving mode within ECONO MODE, the FAN setting automatically switches between Quiet and Low only. Power consumption (*1) and operating sounds are minimised. If the air is clean and the set humidity level has been achieved (when the Humidifying operation is active), after a short while, Monitoring mode automatically activates. Recommended for use during sleep hours.</p> <p>*1 By comparison to AUTO FAN MODE (approx. 10.6Wh), power consumption in ECONO MODE (approx. 6.9Wh) is approx. 3.7Wh lower. Test conditions: operation in 10m² area over 1 hour. Assuming 1 cigarette was smoked immediately after the unit was turned on.</p> <div style="display: flex; justify-content: space-between;"> <div data-bbox="327 952 635 1232" style="border: 1px solid black; padding: 5px;"> <p>Power saving mode</p> <p>FAN setting switches automatically between Quiet and Low.</p> </div> <div data-bbox="646 952 933 1232" style="text-align: center;"> <p>If the air is clean and the set humidity level has been achieved, after a short while...</p>   <p>If the humidity level falls, or dust, or odours are detected...</p> </div> <div data-bbox="944 952 1436 1232" style="border: 1px solid black; padding: 5px;"> <p>Monitoring mode</p> <ul style="list-style-type: none"> The fan starts and stops periodically. Dust, odours, and the humidity level are monitored. The following functions are turned off, further reducing power consumption. <p>Streamer OFF Humidifying OFF (*2)</p> <p>Active plasma ion OFF</p> </div> </div> <p>*2 The humidifier ON/OFF lamp remains lit up.</p> <ul style="list-style-type: none"> As the FAN setting is limited to Quiet and Low, air purifying and humidifying capacity is reduced. As air is not drawn in when the fan has stopped, the dust/PM2.5 sensor, odour sensor, and humidity sensor reduce in sensitivity. To prevent this reduction in sensitivity, turn Monitoring mode OFF. ▶Page 20 FAN setting is adjusted automatically. Airflow cannot be adjusted manually. <ul style="list-style-type: none"> Press  to select the humidity level. 										
<p>ANTI-POLLEN</p>	<p>Reducing pollen levels</p> <p>A gentle air current is created by switching every 5 minutes between the FAN setting Standard and Low so that pollen can be drawn in and caught before it reaches the floor.</p> <ul style="list-style-type: none"> FAN setting is adjusted automatically. Airflow cannot be adjusted manually. <ul style="list-style-type: none"> Press  to select the humidity level. 										
<p>MOIST</p>	<p>Combating dry throat and skin</p> <p>Humidity is automatically adjusted to be gentle on the skin and throat.</p> <ul style="list-style-type: none"> As humidity is kept relatively high, if the temperature difference between outdoors and indoors is large, condensation may result. FAN setting is adjusted automatically. Airflow cannot be adjusted manually. Humidity level is set automatically. Humidity level cannot be selected. <ul style="list-style-type: none"> If  is pressed when MOIST MODE is active, MOIST MODE stops and AUTO FAN MODE is activated. Humidity level will be the level selected previously. <div data-bbox="957 1814 1444 2116"> <p>Room conditions and target humidity</p>  <table border="1"> <caption>Room conditions and target humidity</caption> <thead> <tr> <th>Room temperature (°C)</th> <th>Target humidity (%)</th> </tr> </thead> <tbody> <tr> <td>10</td> <td>70%</td> </tr> <tr> <td>20</td> <td>60%</td> </tr> <tr> <td>25</td> <td>50%</td> </tr> <tr> <td>30</td> <td>40%</td> </tr> </tbody> </table> </div>	Room temperature (°C)	Target humidity (%)	10	70%	20	60%	25	50%	30	40%
Room temperature (°C)	Target humidity (%)										
10	70%										
20	60%										
25	50%										
30	40%										

Useful Functions

Remote controller

Unit



Using the Child Proof Lock

Button operation is restricted preventing misoperation by small children.

Remote controller

Hold down  for about 2 seconds.

Unit

Cannot be set from unit.

• Hold down  for 2 seconds again to turn off child proof lock.

• When Child proof lock is active, operations will be restricted. When buttons are pressed, only a tone (3 short beeps) will sound, preventing misoperation by small children.

Note

- If the unit is unplugged when Child proof lock is active, Child proof lock is turned off.
- The Child proof lock lamp [orange] lights up when the function is active.

Adjusting Indicator Lamp Brightness

Indicator lamp brightness is adjustable.

Remote controller

Press  .

Unit

Cannot be set from unit.

• Press to cycle between settings.



Note

- This function is useful if the lamps bother you during sleep hours etc.
- The ON/OFF lamp and water supply lamp do not turn off even if the brightness is set to OFF. These lamps will be set to DIM.
- If any of the below buttons are pressed when brightness is set to OFF, brightness will change to DIM and return to OFF after about 10 seconds.



Advanced Settings

If the hissing sound generated by the streamer discharge or the smell of ozone bother you



*Setting at time of purchase

Streamer Output Settings

Regular*	Low
----------	-----

Setting procedures **Remote controller**

Hold down  and  for about 3 seconds when the unit is off.

- Each time  and  are held down for about 3 seconds, the setting switches between Regular and Low.

[When the setting is changed to Low]

A short beep sounds and the streamer lamp blinks for about 5 seconds.



[When the setting is changed to Regular]

A short beep sounds and the streamer lamp lights up for about 5 seconds.



Streamer operation status

Streamer output setting		FAN/MODE setting	
		Regular	Low
FAN	Quiet, Low	ON-OFF*	OFF
	Standard		ON-OFF*
	Turbo	ON	ON
MODE	AUTO FAN, ANTI-POLLEN, MOIST	ON-OFF*	ON-OFF*
	ECONO		OFF

*The streamer operation status ON-OFF means that the streamer turns ON and OFF automatically depending on the degree of air impurity and FAN setting.

- The streamer lamp turns off when streamer operation is OFF.

Note

- It is recommended that the streamer be set to Regular as deodorising capacity is reduced when set to Low.
- Settings are remembered even if the unit is unplugged.

When you want to turn off active plasma ion output



*Setting at time of purchase

Active Plasma Ion Output Settings

ON*	OFF
-----	-----

Setting procedures **Remote controller**

Hold down  and  for about 3 seconds when the unit is off.

- Each time  and  are held down for about 3 seconds, the setting switches between ON and OFF.

[When the setting is changed to OFF]

A short beep sounds and the dust lamp, PM2.5 lamp, and odour sensor lamp blink green for about 5 seconds.



[When the setting is changed to ON]

A short beep sounds and the dust lamp, PM2.5 lamp, and odour sensor lamp light up green for about 5 seconds.



Note

- Settings are remembered even if the unit is unplugged.
- If set to OFF, active plasma ion discharge stops, however, dust and odour removal continues.
- If the smell of ozone bothers you, set active plasma ion output to OFF.**
- If the smell of ozone continues to bother you, even after output has been set to OFF, set streamer output to Low.

Advanced Settings

If the tone emitted when the water supply lamp lights up bothers you

*Setting at time of purchase

Notification Tone Setting

ON*

OFF

Setting procedures **Unit**

1. Hold down  for about 3 seconds when the unit is off.

- Each time  is held down for about 3 seconds, the setting switches between ON and OFF.

[When the setting is changed to OFF]

A short beep sounds and the humidity lamp  (Standard) blinks for about 5 seconds.



[When the setting is changed to ON]

A short beep sounds and the humidity lamp  (Standard) lights up for about 5 seconds.

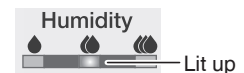

Note

- This function is useful for use during sleep hours etc.
- Settings are remembered even if the unit is unplugged.
- The error notification alarm cannot be turned off.

When the sensitivity of the dust/PM2.5 sensor does not meet your preferences

*Setting at time of purchase



Setting Dust/PM2.5 Sensor Sensitivity

High

Normal*

Low

Setting procedures **Remote controller** **Unit**

1. Hold down  on the unit for about 5 seconds and when a short beep sounds, press  on the remote controller while pressing  on the unit.

- This setting change can be performed when the unit is on or off.

2. Release both buttons when a short beep sounds.

- One of the FAN lamps ( (Low),  (Standard),  (Turbo)) will blink for about 5 seconds and then the lamp corresponding to the currently set sensitivity will light up.

3. Press  on the unit to change the sensitivity setting.

- Each press cycles between the FAN lamps allowing you to change the sensitivity.

To set sensitivity High

▶ Select the FAN lamp  (Turbo).

To set sensitivity Low

▶ Select the FAN lamp  (Low).

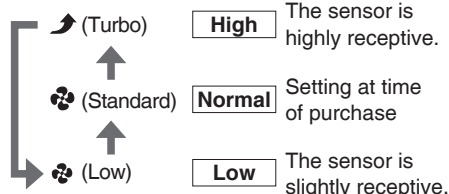

- Setting is indicated using the FAN lamps. If the FAN lamps do not change, unplug the unit, wait at least 5 seconds, then reinsert the power supply plug and repeat the above procedure from the beginning.

4. Press  on the remote controller after selecting the new setting.

- A short beep sounds and the new setting will blink. Unplug the unit while the lamp is blinking, wait at least 5 seconds, and then reinsert the power supply plug. Setting is now complete.
- If this procedure is not performed, the unit will not return to regular operation mode.

Note

- Settings are remembered even if the unit is unplugged.



If you wish to turn Monitoring mode (within ECONO MODE) OFF

*Setting at time of purchase

Settings of Modes within ECONO MODE

Monitoring ON*	Monitoring OFF
----------------	----------------

Setting procedures **Remote controller** **Unit**

1. Hold down  on the unit for about 5 seconds and when a short beep sounds, press  on the remote controller while pressing  on the unit.

- This setting change can be performed when the unit is on or off.

2. Release both buttons when a short beep sounds.

- The FAN lamp  (Quiet) and ECONO MODE lamp will light up after blinking for about 5 seconds. The ECONO MODE lamp will light up or blink depending on the ON/OFF status of Monitoring mode.

3. Press  on the unit to change the setting.

- Each press turns the ECONO MODE lamp ON or OFF. (The FAN lamp  (Quiet) will remain lit up.)

To turn Monitoring mode **ON**
▶ Turn on the ECONO MODE lamp.



Setting at time of purchase

To turn Monitoring mode **OFF**
▶ Turn off the ECONO MODE lamp.



- Setting is indicated using the ECONO MODE lamp. If the ECONO MODE lamp does not change, unplug the unit, wait at least 5 seconds, then reinsert the power supply plug and repeat the above procedure.

4. Press  on the remote controller after making the new setting.

- A short beep sounds and the FAN lamp  (Quiet) will blink. When Monitoring mode is turned ON, the ECONO MODE lamp also blinks. Unplug the unit while the lamp is blinking, wait at least 5 seconds, and then reinsert the power supply plug. Setting is now complete.
- If this procedure is not performed, the unit will not return to regular operation mode.

Note

- Settings are remembered even if the unit is unplugged.

Before cleaning and maintenance work, make sure to unplug the unit. (An electric shock or injury may result)

Maintenance

Maintenance Quick Reference Table

Check the reference pages for details on removing and attaching parts during cleaning/maintenance.

Outflow grille

When dirt becomes an issue

Wipe

Wash/Rinse

- Wipe up dirt with a soft damp cloth and rinse with water.
- Do not use a hard brush etc. (Breakage may result)
- When dirt buildup is severe, leave the part soaking in lukewarm or room temperature water mixed with kitchen-use neutral detergent, thoroughly rinse off the detergent, and leave the part in shade to dry off.

Removing

Place a finger into the notch in the top of the unit and lift.

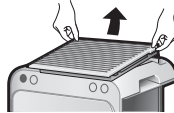

Attaching

Pay attention to orientation and attach securely.

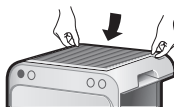

Unit

When dirt becomes an issue

Wipe

- Wipe up dirt with a soft damp cloth.
- When dirt buildup is severe, wet a cloth with kitchen-use neutral detergent and wipe up the dirt.
- Do not use a hard brush etc. (Damage may result)

Pre-filter (Front/Left-side/Right-side)

About every 2 weeks

Vacuum clean

Wash/Rinse

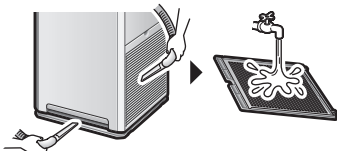

- After removing any dust using a vacuum cleaner, remove and wash the filter with water and then leave it in shade to dry off.
- Use a soft brush when cleaning the spaces in the grid.

Attention

- Do not use a cotton bud or hard brush etc. (Partial breakage of the filter may result)
- Do not apply heavy force. (Partial breakage/damage of the filter may result)
- When dirt buildup is severe, leave the part soaking in lukewarm or room temperature water mixed with kitchen-use neutral detergent, thoroughly rinse off the detergent and leave the part in shade to dry off.

Removing

Grip the indent in the pre-filter and pull.

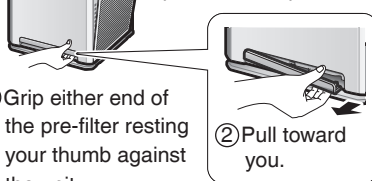

- ① Grip either end of the pre-filter resting your thumb against the unit.
- ② Pull toward you.

Attaching

Insert the hooks (2 places) into the unit and press until a catching sound is heard.

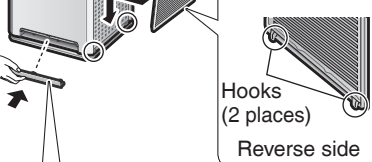

Hooks (2 places)
Reverse side

Insert the hook (1 place) into the unit. Push both ends until securely attached.

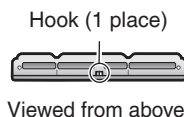

Hook (1 place)
Viewed from above

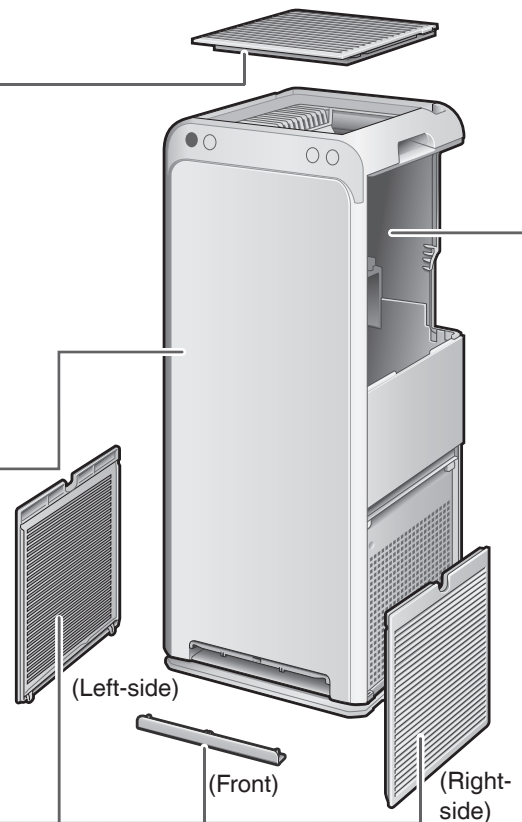

Dust/PM2.5 sensor

When dust has built up

Vacuum clean

- ① Remove the pre-filter (left-side).
- ② Vacuum off any dust that has adhered to the air intake for dust/PM2.5 sensor using the vacuum cleaner crevice tool or similar.

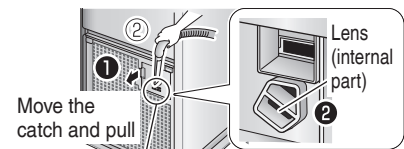

Air intake for dust/PM2.5 sensor

About every 3 months **Wipe**

- ① Remove the pre-filter (left-side) and the cover for the air intake for dust/PM2.5 sensor.
- ② Wipe the lens with a dry cotton bud.

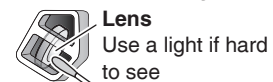

Lens
Use a light if hard to see

Use the vacuum cleaner crevice tool or similar to remove any dust that has built up around the lens.

- ③ Place the cover on securely. (Malfunction may result if the cover is off)

! WARNING

- Do not use petrol, benzine, thinner, polishing compound, paraffin, alcohol, etc. (An electric shock, fire, or cracking may result)
- Do not wash the main body of the unit with water. (An electric shock, fire, or malfunctioning/breakage may result)

Water tank ▶Page 11

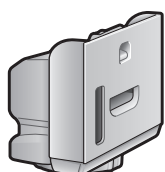

[Inside the water tank]
Every time the water tank is refilled

Wash/Rinse

- Clean the water tank by filling it with a small amount of water, closing the cap, and shaking.
- When dirt is hard to remove, clean with a soft brush or diluted kitchen-use neutral detergent and thoroughly rinse off the detergent.

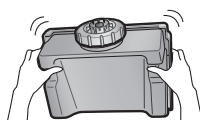

[Exterior of water tank]
When dirt on the exterior of the water tank becomes an issue

Wipe

- Wipe up dirt with a soft damp cloth.
- When dirt buildup is severe, wet a cloth with kitchen-use neutral detergent and wipe up the dirt.



Humidifying filter unit For details on cleaning and removal/attachment, refer to ▶Page 23, 24

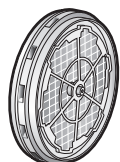

About every 1 week or when smell or dirt becomes an issue

Soak

Each season or when water scales (white and brown) are hard to remove

Soak in citric acid or lemon juice

About every 10 years

Replace

Humidifying tray For details on cleaning and removal/attachment, refer to ▶Page 23

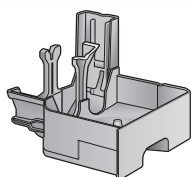

About every 3 days or when smell or dirt becomes an issue

Wash/Rinse

Deodorising filter unit ▶Page 26

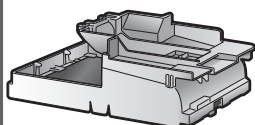

When dirt becomes an issue **Vacuum clean**

- Remove from the unit together with the frame and remove dust using a vacuum cleaner.
- If odour becomes an issue, wet the surface lightly with an atomiser etc., and then leave the part to dry in a shaded area with good ventilation. (about 1 day)
- Do not scrub the surface.
- Do not use water when cleaning. (If water is used, the part will lose its shape and become unusable.) ▶Page 29

Do not use water

Do not detach the deodorising filter from frame

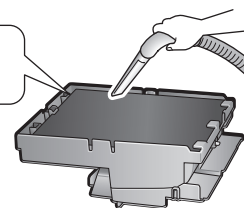

Dust collection filter ▶Page 26

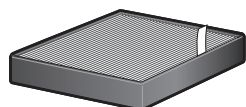

About every 10 years **Replace**

Do not use water

Do not vacuum clean

- Do not use a vacuum cleaner or use water when cleaning. (If the filter is damaged or holes are opened etc., dust will pass through the filter and capacity for dust collection will be reduced.)

Attention

- If detergent was used, make sure to wipe it up thoroughly so none remains.
- If hot water is used, make sure that it is 40°C or less.
- Do not leave parts to dry in direct sunlight.
- Do not dry parts using a dryer.
- Do not apply fire to parts. Discolouration or deformation will result, making the part unusable.
- If using a vacuum cleaner, make sure to not apply force to or knock the part. (Damage may result)

Maintenance

! WARNING

Before cleaning and maintenance work, make sure to unplug the unit. (An electric shock or injury may result)

Removing the humidifying tray and humidifying filter unit

1. Remove the water tank. [▶Page 11](#)
2. Pull out the humidifying tray and then remove the humidifying filter unit.

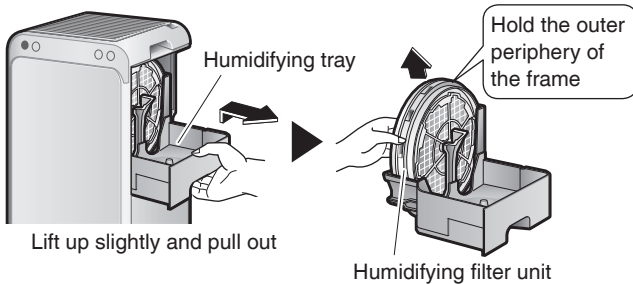

Lift up slightly and pull out

- Pull out the tray gently as if there is any water inside, the water surface may ripple and it may spill out.
- When carrying, hold the base of the humidifying tray.

Attaching the humidifying tray and humidifying filter unit

1. Attach the humidifying tray and humidifying filter unit.

① Attach the humidifying filter unit.

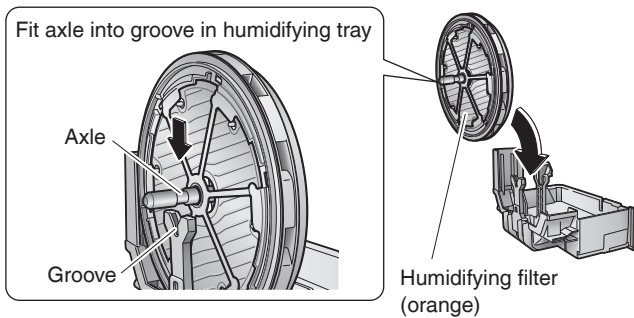

② Push the humidifying tray all the way in.

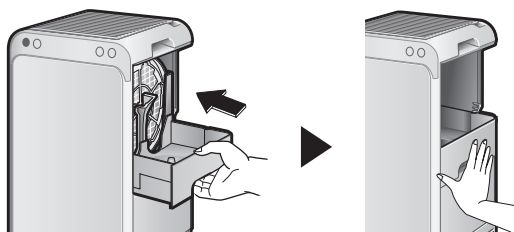

- If the humidifying filter unit is not correctly attached to the humidifying tray, the humidifying tray cannot be attached to the unit.

Attention

After attaching the humidifying tray to the unit, do not forcibly rotate the humidifying filter unit. Malfunctioning may result.

2. Attach the water tank. [▶Page 11](#)

About every 3 days or when odour or dirt becomes an issue

Humidifying tray

Clean with water.

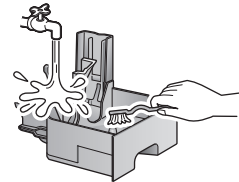

- Use a soft cloth or brush to clean hard-to-reach places.
- If there are water scales on the tray, mix some citric acid in lukewarm or room temperature water. Soak a soft cloth or brush in the water, clean the affected area, and then rinse with water.
- Be careful not to immerse the silver ion cartridge in lukewarm or room temperature water in which citric acid has been dissolved. Doing so will result in loss of the capacity for slime-resistance.
- Citric acid may be purchased at a pharmacy or drug store.
- Depending on water quality and the usage environment, water in the humidifying tray may become discoloured due to water scales etc. In such cases, clean the tray in accordance with the above.

About float and silver ion cartridge

- **Do not remove the float or silver ion cartridge.**
 - If the float is removed, the Humidifying operation cannot be run.
- If the silver ion cartridge is removed, capacity for slime-resistance is diminished.

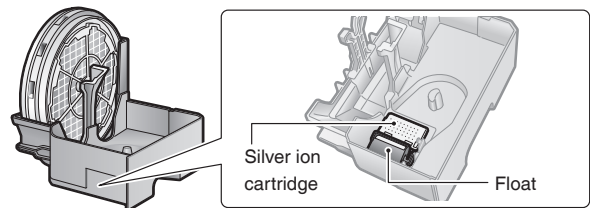

If the float detaches from the tray

Protrusion on tray Protrusion on float ① Place the float protrusion onto the tray protrusion

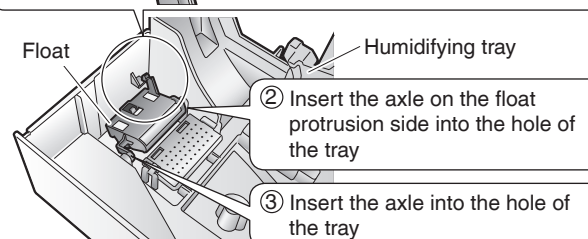

Protrusion on tray

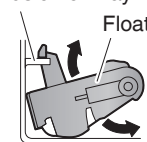

- Check the smooth movement of the float after the attachment.
- If the float rises to the water surface when the tray is filled with water, it has been attached correctly.

When dirty, the humidifying tray and humidifying filter may give off bad odours. Make sure to clean them periodically.

About every 1 week or when odour or dirt becomes an issue

Humidifying filter unit

Clean by soaking in lukewarm (about 40°C or less) or room temperature water.

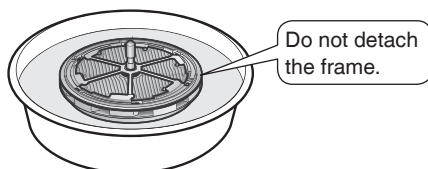

Each season or when water scales (white and brown) are hard to remove

If water scales are not removed and the unit continues to be operated, reduced humidifying capacity and water leakage may result.

Each season clean using citric acid or lemon juice.

Humidifying filter unit

Soak in lukewarm (about 40°C or less) or room temperature water mixed with citric acid or lemon juice for about 2 hours.

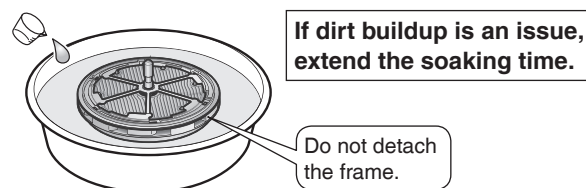

Usage quantities for citric acid:
approx. 20g of citric acid (2 tablespoons) in 3L of water

- Citric acid may be purchased at a pharmacy or drug store.

Usage quantities for lemon juice:

1/4 cup of lemon juice per 3 cups of water

- 100% bottled lemon juice can be used. Use only 100% bottled lemon juice with no pulp (strain juice if necessary).
- If you squeeze a lemon, make sure there are no pieces of peel or pips.

Precautions when cleaning humidifying filter unit

- Do not use force when cleaning the humidifying filter. (Deformation may result)
- Clean by scrubbing gently with a soft sponge.
- Do not use a brush or scrub with force.
- To prevent bad odours and discolouration, make sure to thoroughly rinse off the parts with clean water.
- The parts can be used even if still wet after cleaning.
- If the parts are not to be used for a long period of time, leave them in shade to dry off thoroughly.

When odours or dirt are hard to remove

Soak the parts for about 30 to 60 minutes in lukewarm (about 40°C or less) or room temperature water mixed with kitchen-use neutral detergent.



- Observe the quantities indicated in the directions/warnings on the detergent when using detergent.
- Discolouration may result from the usage of detergent, however, this is not a problem.
- After soaking, thoroughly rinse the parts.

When dirt inside the unit is an issue

When the water tank is removed, you may find that the inside of the unit is stained white. Such stains are chlorine compounds resulting from water vaporisation. They are normal. If the stains are an issue, they can be removed.

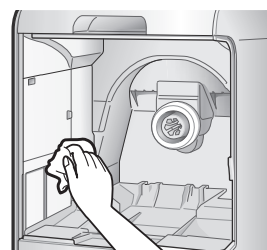

- Wipe away the stains using a soft damp cloth.
- If the staining is severe, wipe the stains using a cloth moistened with kitchen-use neutral detergent.
- Do not use a hard brush etc. (Breakage may result)

Attention

Dirt buildup varies by the usage environment of the humidifying filter.

It is recommended that you clean the parts if you notice an odour from the air outlet or a reduction in humidifying capacity (water usage rate).

Maintenance

⚠ WARNING

Before cleaning and maintenance work, make sure to unplug the unit. (An electric shock or injury may result)

Humidifying filters Replace

Replace about every 10 years*

About part replacement timing

- Replacement timing depends on usage patterns and the location of the unit. Standard replacement time is about 10 years assuming that the filters are used 8 hours per day, 6 months per year, and are cleaned periodically. Replace the humidifying filters if dirt/stains cannot be removed or there is a reduction in humidifying capacity (water usage rate).

Humidifying filter unit parts breakdown

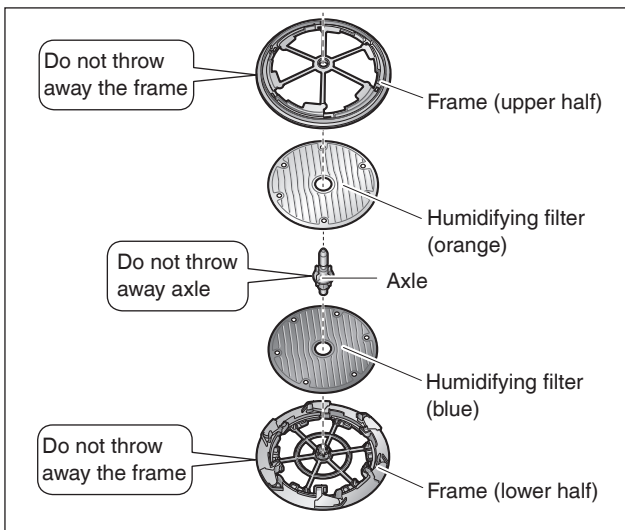

1. Remove the frame and axle.

- ① Release the frame hooks (6 places).

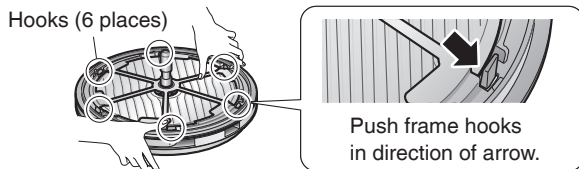

- ② Remove the frame (upper half) and pull out the axle from the frame (lower half).

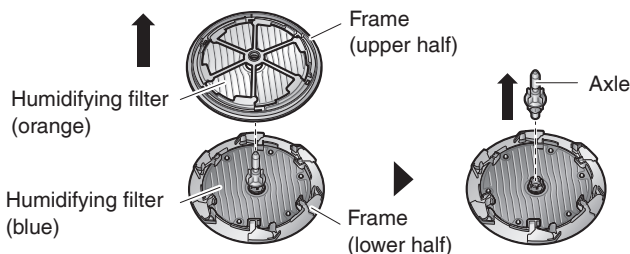

2. Remove the humidifying filters.

- Detach the humidifying filters from each frame.

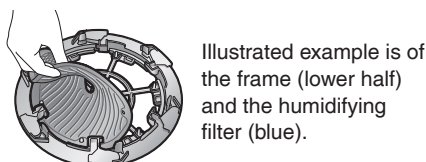

* Time until humidifying capacity drops to 50% of the rated humidifying capacity

About purchasing and disposal

- Refer to "Separately Sold Parts". ▶Page 27

3. Attach the new humidifying filters to each frame. (Both humidifying filters have a front and back.)

- Align the projections (6 places) on each frame with the holes in each filter. (Water leakage may result if not correctly attached.)

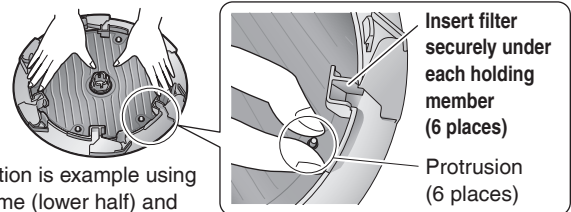
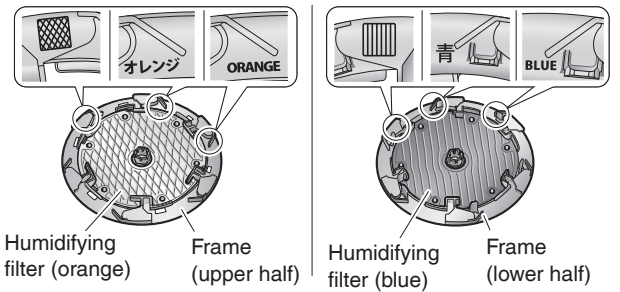

Illustration is example using the frame (lower half) and the humidifying filter (blue).

Filter and frame combinations

- Attach the filters to the frames so that the colour and weaving pattern of each filter matches the markings on the frame.



4. Attach the frames and axle.

- ① Align the grooves in the frames (upper half and lower half) with the projections on the axle when attaching.

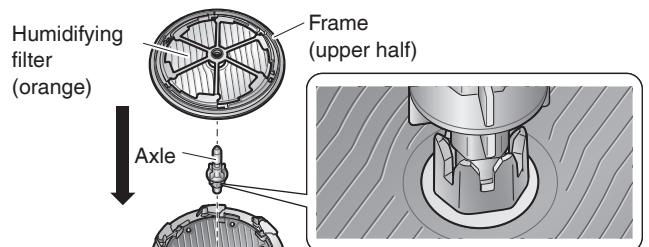

- ② Insert the hooks (6 places) until a catching sound is heard.

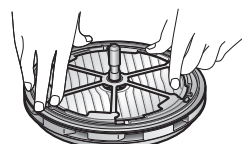

Attention

Make sure that the dust collection filter and deodorising filter unit are attached to the unit when the unit is operating. If these parts are not attached when the unit is operated, breakage/malfunctioning may result.

Dust collection filter **Replace**

Replace about every 10 years

About part replacement timing

- Replacement timing depends on usage patterns and the location of the unit.
If the unit is used daily in a home where 5 cigarettes are smoked a day, the filter should be replaced about every 10 years. (Calculation based on testing method of Japan Electrical Manufacturers Association JEM1467 standard.)
If the impurity content of the ambient air is high, the filter will need more frequent replacement.
If the filter is failing to perform, it is time to replace it.

About purchasing and disposal

- Refer to "Separately Sold Parts". ▶Page 27

1. Remove the water tank. ▶Page 11

2. Pull out the humidifying tray and humidifying filter unit. ▶Page 23

3. Remove the deodorising filter unit.

- ① Move the lever on the deodorising filter unit to  to unlock it.

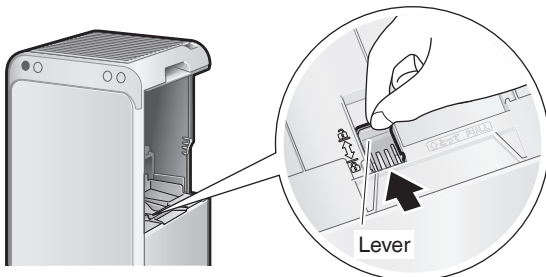

- ② Hold the grip at the top of the deodorising filter unit and lift the part up and out.

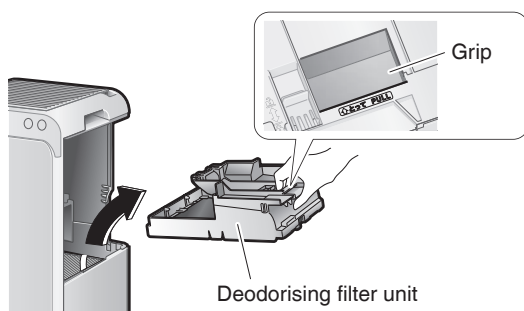

4. Remove the dust collection filter.

- ① Pull the tag upward. ② Hold the lower part of the dust collection filter and lift it out.

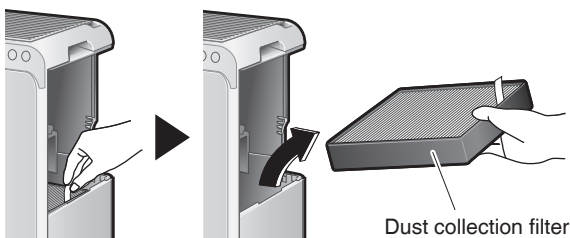

5. Install a new dust collection filter.

- If it is hard to install, push the dust collection filter while installing.

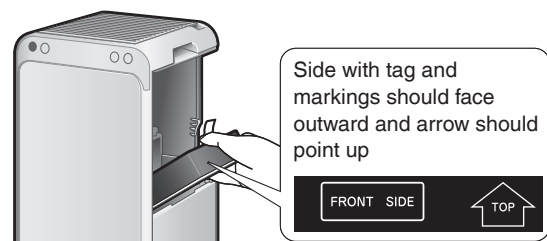

6. Attach the deodorising filter unit.

- Attach the deodorising filter unit and move the lever to  to lock it.

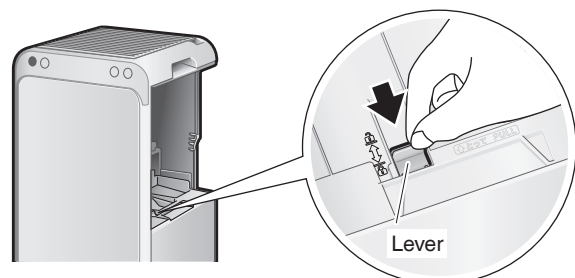

Attention

Make sure to lock the deodorising filter unit. If it is not locked when the unit is operated, abnormal noise and reduced performance may result.

7. Attach the humidifying tray and humidifying filter unit. ▶Page 23

8. Attach the water tank. ▶Page 11

Before cleaning and maintenance work, make sure to unplug the unit. (An electric shock or injury may result)

Maintenance

Separately Sold Parts

Contact the place of purchase.

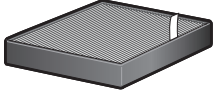
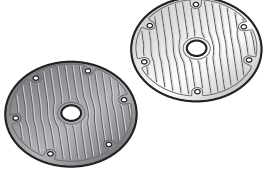
Replacement part	Replacement part
<p>Dust collection filter (electrostatic HEPA filter) (1 piece) Model: KAFP080B4E</p>	<p>Humidifying filters (without frame) (Orange: 1 piece, Blue: 1 piece) Model: KNME080A4E</p>
	
<ul style="list-style-type: none"> • Replace about every 10 years. • Catches dust and pollen. 	<ul style="list-style-type: none"> • Replace about every 10 years. • Humidify air by vaporising water during the Humidifying operation.

- Failure to clean parts properly could result in:
 - Reduced air purifying capacity.
 - Reduced deodorising capacity.
 - Emission of odours.
- Observe local waste separation rules when disposing of the dust collection filter (made of polyester and polypropylene) and the humidifying filters (made of polyester).

When Not Using the Unit for Long Time Periods

- 1. Remove the power supply plug.**
- 2. Discard any water in the water tank and humidifying tray and then clean the parts.** ▶ Page 21, 22
- 3. Leave internal components in a shaded area to dry.**
 - In particular, components cleaned with water should be completely dry. (Mould may result from remaining moisture)
- 4. Cover the air outlet and other openings with a plastic bag or similar to prevent dust entry, and store the unit upright in a dry place.**
(Malfunctioning/breakage may result from storing the unit upside down or on its side)

If not using the Humidifying operation for a long time (during off-season etc.)





- 1. Remove the power supply plug.**
- 2. Discard any water in the water tank and humidifying tray and then clean the parts.** ▶ Page 21, 22
- 3. Leave internal components in a shaded area to dry.**
 - In particular, components cleaned with water should be completely dry. (Mould may result from remaining moisture)
- 4. Insert the power supply plug into the socket.**
- 5. Run the air purifying operation.**

About the Indicator Lamps

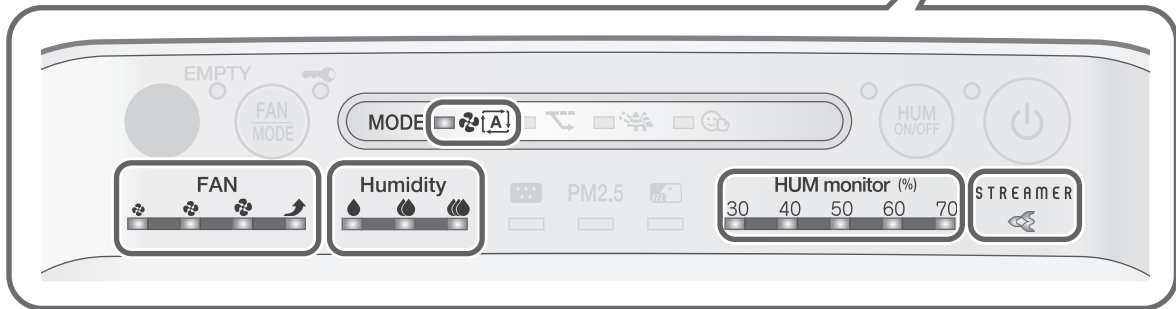
Operating/Indicator panel

Check the indicator lamps and respond as indicated below.



Indicator lamp	Cause/Solution	
<p>Streamer lamp</p> <p>3 long beeps sound and the lamp blinks.</p> 	<p>This lamp blinks if the deodorising filter unit has become detached or is not attached properly. → Attach the deodorising filter unit properly. (▶Page 26)</p>	
<p>HUM monitor lamp</p> <p>3 long beeps sound and all 5 lamps blink at the same time.</p> 	<p>An electrical component is faulty. → Contact the place of purchase.</p>	
<p>AUTO FAN MODE lamp</p> <p>3 long beeps sound and the lamp blinks.</p> 		
<p>Humidity lamp</p> <p>3 long beeps sound and all 3 lamps blink at the same time.</p> 	<p>The temperature sensor or the humidity sensor is faulty. → Contact the place of purchase.</p>	
<p>FAN lamp</p> <p>3 long beeps sound and all 4 lamps blink at the same time.</p> 	<p>Are the pre-filter, outflow grille, dust collection filter, humidifying filter unit, humidifying tray, and water tank attached? These lamps may blink if the unit is operated without a part attached.</p>	<p>■ If all parts are attached An electrical component is faulty. → Contact the place of purchase.</p> <p>■ If one or more components are not attached Remove the power supply plug, reattach the parts and then turn the unit on again.</p>
<p>Is there a buildup of dust on the pre-filter?</p>	<p>■ If there is no dust buildup An electrical component is faulty. → Contact the place of purchase.</p> <p>■ If there is a dust buildup Remove the power supply plug, clean the pre-filter and then turn the unit on again. (▶Page 21)</p>	
<p>Is the air outlet blocked?</p>	<p>■ If the air outlet is not blocked An electrical component is faulty. → Contact the place of purchase.</p> <p>■ If the air outlet is blocked Remove any obstacles blocking the air outlet and then turn the unit on again.</p>	
<p>These lamps may blink if there is a sudden drop in voltage.</p>		

FAQs

Please check the following before contacting us.

Q: The dust/PM2.5 sensor seems to have poor sensitivity...

A: Perform periodic cleaning of the dust/PM2.5 sensor as dirt on its lens can lead to poor sensitivity. [▶Page 21](#)
 In addition, the response time of the dust/PM2.5 sensor varies depending on room size. Make adjustments in accordance with the procedure for setting dust/PM2.5 sensor sensitivity. [▶Page 19](#)
 The responsiveness of the dust/PM2.5 sensor may be poor during FAN setting “Turbo” or when airflow is high in AUTO FAN MODE or MOIST MODE.
 The strong airflow causes dust to be drawn into the air inlet before it can be detected by the dust/PM2.5 sensor. This is normal (not a malfunction).

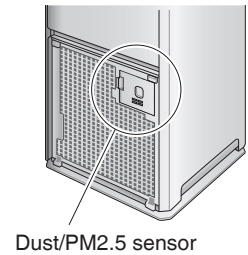

Dust/PM2.5 sensor

Q: Can the dust collection filter be cleaned?

A: No. Do not attempt to clean it with a vacuum cleaner or water.
 (Reduced performance of the dust collection filter may result)
 Replace it if dirt buildup is severe.

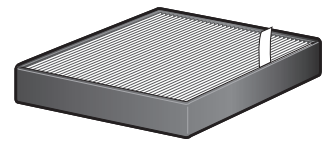

Q: The dust collection filter easily turns black...

A: The blackening does not affect dust collection performance. However, it can be replaced if it is an issue.

Q: Can the deodorising filter be cleaned with water? Or should it be replaced?

A: It cannot be cleaned with water.
 (If water is used, the part will lose its shape and become unusable.)
 If you have inadvertently washed it with water, consult the place of purchase.
 Remove the deodorising filter unit from the main body and vacuum off dust with a vacuum cleaner.
 It is not necessary to replace the filter.
 If odour becomes an issue, wet the surface lightly with an atomiser etc., and then leave the part to dry in a shaded area with good ventilation. (about 1 day)

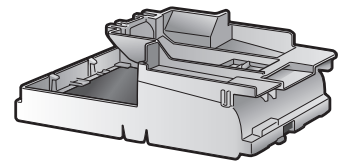

[▶Page 22](#)

Q: No steam is visible during the Humidifying operation...

A: No steam is visible because humidification is achieved by passing air through the humidifying filter and vaporising, rather than by boiling water.

Q: Air emitted during the Humidifying operation feels cool...

A: Emitted air is a little lower in temperature than the air drawn-in because heat in the air is consumed when the water contained in the humidifying filter is vaporised.

Q: Humidification is in progress but ambient humidity is not rising...

A: It may take time for humidity to rise depending on room size and conditions. Select the humidity setting  (High) and increase the airflow rate. [▶Page 33](#)
 Dirt buildup on the humidifying filter can cause reduced performance. Perform periodic cleaning/maintenance. [▶Page 24](#)

Q: Is it not necessary to replace the silver ion cartridge attached to the humidifying tray?

A: The silver ion cartridge has a service life of 10 years.

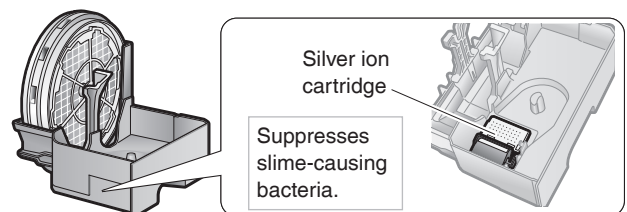

Silver ion cartridge
 Suppresses slime-causing bacteria.

Troubleshooting

■ **Before making an inquiry or a request for repair, please check the following.**

If the problem persists, contact the place of purchase.

■ **In the event of malfunction during operation**

If the indicator lamps light up abnormally, or become inoperable, due to a lightning strike etc., remove the power supply plug, wait at least 5 seconds then reinsert the power supply plug and turn the unit on again.



Not a problem



This case is not a problem.











Check

Please check again before requesting repairs.

■ **Unit does not respond**





Phenomenon	Check points
No response even if  on the remote controller is pressed	<ul style="list-style-type: none">  • Has the battery run out? → Replace the battery. ▶Page 12 • Is a button on a remote controller for a TV, VCR, or other appliance, stuck pressed down? → If a button on another remote controller is stuck pressed down because it is pressed against a remote controller rack etc., it may interfere with reception. • Is there a device in the room that redirects remote controller signals? → Some appliances such as TV speakers are equipped with such devices. If there is such a device in the room, the signals it emits may interfere with signals from the remote controller, preventing reception.
	<ul style="list-style-type: none">  • To protect the system, the unit may stop operating after sudden large voltage fluctuations. If operating at the time, operation will resume automatically once voltage returns to normal. Voltage range protection: 180V-264V

■ **Sounds can be heard**

Phenomenon	Check points
Catching sound during Humidifying operation	<ul style="list-style-type: none">  • A catching sound may be generated when the Humidifying operation starts/stops.
Bubbling sound during Humidifying operation	<ul style="list-style-type: none">  • A bubbling sound may be generated when water is supplied from the water tank to the humidifying tray.
Sizzling or rumbling sounds during Humidifying operation	<ul style="list-style-type: none">  • These sounds are generated when the humidifying filter unit rotates during the Humidifying operation. If the sounds are an issue, try moving the unit to a different location.
Creaking sound during Humidifying operation	<ul style="list-style-type: none">  • Is the humidifying tray or humidifying filter unit dirty? → A sound may be generated when there is a buildup of water scales on the humidifying tray or humidifying filter unit. Clean these parts. ▶Page 23, 24
Splashing sound during Humidifying operation	<ul style="list-style-type: none">  • This is the sound of water splashing on to the humidifying filter.
Hissing sound during operation	<ul style="list-style-type: none">  • This is the sound of streamer discharge during streamer operation. Depending on usage conditions, the sound may fall in volume or change to a crackling, whirring, or guzzling sound, however, this is normal. If the sounds are an issue, try moving the unit to a different location. ▶Page 18
Whistling and fluttering sound during operation	<ul style="list-style-type: none">  • Is there a buildup of dust on the pre-filter? → Clean this part. ▶Page 21 • Is the dust collection filter clogged up? → Depending on usage conditions, the dust collection filter may become clogged up, shortening its service life. ▶Page 5 Replace the dust collection filter. ▶Page 26
Operating sound is loud	<ul style="list-style-type: none">  • Is the dust collection filter attached properly? → If it is not properly attached, operating sounds may become louder. ▶Page 26

Troubleshooting

Indicator lamps

Phenomenon	Check points
<p>The water supply lamp turns on and off repeatedly</p>	<p><input checked="" type="checkbox"/> • Even after the water supply lamp has turned on, depending on the FAN setting, water in the humidifying tray may ripple and move the float causing the water supply lamp to turn on and off repeatedly. (This is because the on/off status of the water supply lamp is dependent on float position.) → Fill the water tank with water. (▶Page 11)</p>
<p>Indicator lamps do not light up Indicator lamps turn off about 10 seconds after the unit is turned on</p>	<p><input type="checkbox"/> • Is indicator lamp brightness set to OFF? → If indicator lamp brightness is set to OFF, all lamps except the ON/OFF lamp and water supply lamp will remain off. → If indicator lamp brightness is set to OFF, after the unit is turned on, the brightness of the indicator lamps will be DIM for about 10 seconds and then turn OFF. (▶Page 17)</p>
<p>All the FAN lamps () (Quiet), ) (Low), ) (Standard), and ) (Turbo)) blink together</p>	<p><input type="checkbox"/> • Are the pre-filter, outflow grille, dust collection filter, humidifying filter unit, humidifying tray, and water tank attached? These lamps may blink if the unit is operated without a part attached. [If one or more parts are not attached] → Remove the power supply plug, reattach the parts and then turn the unit on again. [If all parts are attached] An electrical component is faulty. → Contact the place of purchase.</p> <p>• Is there a buildup of dust on the pre-filter? [If there is a dust buildup] (▶Page 21) → Remove the power supply plug, clean the pre-filter and then turn the unit on again. [If there is no dust buildup] An electrical component is faulty. → Contact the place of purchase.</p> <p>• Is the air outlet blocked? [If the air outlet is blocked] → Remove any obstacles blocking the air outlet and then turn the unit on again. [If the air outlet is not blocked] An electrical component is faulty. → Contact the place of purchase.</p> <p><input checked="" type="checkbox"/> • These lamps may blink if there is a sudden drop in voltage. The lamps will return to their previous condition once voltage returns to normal. Voltage range protection: 180V-264V</p>
<p>The dust/PM2.5 sensor lamp remains orange or red</p>	<p><input type="checkbox"/> • Is there a buildup of dust in or around the air intake for the dust/PM2.5 sensor? → Vacuum off any dust from the air intake using a cleaner. (▶Page 21)</p> <p>• Is the cover detached from the air intake for the dust/PM2.5 sensor? → Securely attach the cover. (▶Page 21)</p> <p>• Is the lens for the dust/PM2.5 sensor dirty? → Wipe off dirt from the lens using a dry cotton bud or similar. (▶Page 21)</p> <p>• Is the pre-filter dirty? (▶Page 21) → After cleaning, the unit will return to normal operation a short while after being turned on.</p>
<p>The water supply lamp remains on even though water was added</p>	<p><input type="checkbox"/> • Is the float in the humidifying tray stuck due to a buildup of water scales? → Remove the water scales using a brush or similar. (▶Page 23)</p> <p>• Is the humidifying tray securely attached? → Insert it securely into the unit until a click is heard.</p> <p>• Is the float in the humidifying tray detached? → Attach the float. (▶Page 23)</p>

Indicator lamps



Phenomenon	Check points
There is an odour but the odour sensor lamp remains green	<p>?</p> <ul style="list-style-type: none"> • Did an odour emerge around the time you inserted the power supply plug? → The sensitivity of the odour sensor will be determined by odour levels in the first minute (approx.) after the power supply plug is inserted. ▶Page 7, 8 <p>When the air is clean (i.e. there are no odours), remove the power supply plug. Wait at least 5 seconds then reinsert the power supply plug and turn the unit on again. This process adjusts the reference odour level that determines the sensitivity of the odour sensor.</p>
Sometimes the streamer lamp does not light up	<p>✓</p> <ul style="list-style-type: none"> • Depending on the degree of air impurity, streamer operation may turn OFF. The streamer lamp turns off when streamer operation is OFF.
	<p>?</p> <ul style="list-style-type: none"> • Is streamer output set to Low? → If it is set to Low, the operating status of the streamer can change according to the FAN setting which influences the on/off status of the streamer lamp. ▶Page 18 • Is the unit operating in ECONO MODE? → The streamer lamp does not light up when the unit is in Monitoring mode. ▶Page 16
The streamer lamp blinks	<p>?</p> <ul style="list-style-type: none"> • Is the deodorising filter unit attached? → Attach the deodorising filter unit. ▶Page 26

Air purifying function

Phenomenon	Check points
Air purifying capacity is reduced	<p>?</p> <ul style="list-style-type: none"> • Is the unit positioned in a place where airflow cannot reach or surrounded by obstacles? → Choose a position that is obstacle-free and from where airflow can reach all areas of the room. • Is the pre-filter or dust collection filter dirty? → Clean these parts. ▶Page 21, 22
The air outlet is emitting an odour	<p>?</p> <ul style="list-style-type: none"> • Is the deodorising filter, humidifying filter, or humidifying tray dirty? → Clean these parts. ▶Page 22-24 • Discard any water in the humidifying tray each time you refill the water tank. • When using the Air purifying operation only, discard any water in the water tank and humidifying tray. • In some cases the air outlet may emit a slight odour as trace amounts of ozone are generated. However, the amount is negligible and is not harmful to your health. • Is the room filled with odours due to cooking or several people smoking together etc? → The odour will gradually fade as the unit operates. • Have you moved the unit from another room? → The unit may emit the odour of the room in which it was used previously. Let the unit run a while longer. • Is there anything in the room that is giving off an odour continuously? (Paint, new furniture, wallpaper, sprays, cosmetics, chemicals) → As continuously emitted odour cannot be completely eliminated, you should ventilate the room at the same time or run the unit in a well-ventilated room for a short while.
No air is being emitted	<p>?</p> <ul style="list-style-type: none"> • Is the air outlet or an air inlet blocked? If they are not blocked, the fan motor is faulty. → Contact the place of purchase.

Troubleshooting

■ Humidifying function

Phenomenon	Check points
<p>Humidification does not occur even though the water tank contains water</p> <p>The water in the water tank is not getting used up</p>	<ul style="list-style-type: none"> <input checked="" type="checkbox"/> • Since this unit achieves humidification through vaporisation, the water gets used up slowly when ambient humidity is high or the temperature is low. • The Humidifying operation stops when room humidity reaches the target humidity set for the Humidifying operation. ▶Page 14 <hr/> <ul style="list-style-type: none"> <input type="checkbox"/> • Is the humidifier ON/OFF lamp lit? → If the lamp is not lit, press  or . • Is the humidifying filter unit attached properly? ▶Page 23, 25 • Are there any water scales or dirt on the humidifying filter? → Water scales or dirt buildup on the humidifying filter can cause reduced performance. Dirt buildup on the humidifying filter varies according to water quality and may result in reduced performance. Clean the humidifying filter unit. ▶Page 23, 24 • Is the water supply lamp lit? → If it is lit, the humidifying tray is not attached properly. Reattach the humidifying tray. ▶Page 23 • Is the streamer lamp blinking? → If it is blinking, the deodorising filter unit is not attached properly. Reattach the deodorising filter unit. ▶Page 26
<p>The HUM monitor lamp always indicates a high humidity level</p>	<ul style="list-style-type: none"> <input type="checkbox"/> • Is the unit positioned next to a window or in a location exposed to cold wind? → There is a possibility that only the air surrounding the unit is of high humidity. Move the unit to a different location. <hr/> <ul style="list-style-type: none"> <input checked="" type="checkbox"/> • Humidity builds up easily in north facing rooms or rooms close to wet areas, such as the bathroom, so these rooms tend to have a higher humidity.
<p>The humidity level indicated on the unit differs from other hygrometers</p>	<ul style="list-style-type: none"> <input checked="" type="checkbox"/> • This is because the flow of air causes temperature and humidity to vary throughout the room. Please consider the indications to be a rough estimate of ambient humidity.
<p>Ambient humidity does not rise</p>	<ul style="list-style-type: none"> <input checked="" type="checkbox"/> • When indoor or outdoor humidity is low, the walls and floor of the room are dry, or the room has poor insulation against drafts, the target humidity may not be readily achieved. <hr/> <ul style="list-style-type: none"> <input type="checkbox"/> • Is the target humidity set low? Is the FAN setting low? → Select the humidity setting  (High) and increase the airflow rate. ▶Page 14
<p>Room humidity is high but Humidifying operation does not stop</p>	<ul style="list-style-type: none"> <input checked="" type="checkbox"/> • When indoor or outdoor humidity is high, the walls and floor of the room are moist, or the room has good insulation against drafts, the target humidity may be exceeded. • Air purification is always performed with the Humidifying operation. When the humidity set for the Humidifying operation is reached, the Humidifying operation stops but the Air purifying operation continues. <hr/> <ul style="list-style-type: none"> <input type="checkbox"/> • Is the unit exposed to direct sunlight or warm air from a heating appliance? → Move the unit to a location without such direct exposure.
<p>Water in the water tank is decreasing even though Humidifying operation is not running</p>	<ul style="list-style-type: none"> <input checked="" type="checkbox"/> • Even when only the Air purifying operation is running, if there is water remaining in the water tank, the water may decrease due to spontaneous evaporation and cause slight air humidification. When using the Air purifying operation only, discard any water in the water tank and humidifying tray.

■ Humidifying function

Phenomenon	Check points
Water splashes out from the air outlet	<ul style="list-style-type: none"> ? • Are the pre-filter, outflow grille, dust collection filter, deodorising filter unit, humidifying filter, and water tank attached properly? → Attach them properly. • When removing the humidifying filters from their frames and replacing them, did you do the following? <ul style="list-style-type: none"> • Correct the shape of the filters? • Attach both filters? • Attach the filters to the frames so that the colour and weaving pattern of each filter matches the markings on the frame? → Attach them properly. ▶Page 25

■ Other

Phenomenon	Check points
The fan stops midway through unit operation	<ul style="list-style-type: none"> ✓ • When the unit switches to Monitoring mode during operation in ECONO MODE, the fan turns on and off repeatedly. ▶Page 16
	<ul style="list-style-type: none"> ? • Are the pre-filter, outflow grille, dust collection filter, humidifying filter unit, humidifying tray, and water tank attached before the unit is operated? The fan is configured to stop in order to protect electrical components if a part is not properly attached. → If a part is not attached, unplug the unit and attach all parts before turning the unit on again.
The sound of streamer discharge can no longer be heard	<ul style="list-style-type: none"> ✓ • Depending on the degree of air impurity, streamer operation may turn OFF. ▶Page 18
	<ul style="list-style-type: none"> ? • Is streamer output set to Low? ▶Page 18
There is water spilled on the floor	<ul style="list-style-type: none"> ? • Have you tilted the unit? → If you tilt the unit, water may spill out. Before moving the unit, turn off the power and discard any water in the water tank and humidifying tray. • Is the cap for the water tank loose? → If the cap is loose, water may leak. Tighten it securely before use. • Is there a large buildup of water scales on the humidifying filter? → Water leakage may result from water scale buildup. Clean the part. ▶Page 23, 24
There is interference on our TV screen	<ul style="list-style-type: none"> ? • Is the TV or radio positioned within 2m of the unit, or is an indoor antenna positioned near the unit? • Are the power supply cord or antenna cable of the TV or radio routed near the unit? → Keep the unit as far as possible from the TV, radio, or antenna.
Just inserting the power plug causes operation to start	<ul style="list-style-type: none"> ? • Did you disconnect the power plug during a power failure, or when a sudden voltage fluctuation occurred, to move the unit or disconnect the power plug during the last operation? → The auto-restart function automatically resumes operation.

Specifications / Spesifikasi

Model name/ Nama model	MCK55TVM6							
Power supply/ Catu daya	Single phase 50Hz 220-240V / 60Hz 220-230V/ Satu fasa 50 Hz 220-240 V / 60 Hz 220-230 V							
Operation mode/ Mode pengoperasian	Air Purifying/ Pelembapan Udara				Humidifying and Air Purifying (at indoor temp.: 20°C, indoor humidity: 30%)/ Pelembapan dan Pemurnian Udara (pada suhu dalam-ruang: 20 °C, kelembapan dalam-ruang: 30 %)			
	Turbo/ Turbo	Standard/ Standar	Low/ Rendah	Quiet/ Senyap	Turbo/ Turbo	Standard/ Standar	Low/ Rendah	Quiet/ Senyap
Power consumption (W)/ Konsumsi daya (W)	56	17	10	7	58	19	14	11
Operating sound (dB)/ Suara pengoperasian (dB)	53	39	29	19	53	39	33	25
Airflow rate (m ³ /h)/ Laju aliran udara (m ³ /jam)	330	192	120	54	330	192	144	102
Humidifying rate (mL/h)/ Laju pelembapan (mL/jam)	-				500			
Coverage area (m ²)/ Luas jangkauan (m ²)	-				-			
	41				Japanese-style room in wooden house/ 14 Ruangan bergaya Jepang di rumah kayu Room in prefabricated house/ 23 Ruangan di rumah prapabrikasi (langsung rakit)			
External dimensions (mm)/ Dimensi eksternal (mm)	700(H)× 270(W)× 270(D)/ 700(P)× 270(L)× 270(T)							
Weight (kg)/ Berat (kg)	9.5 (when water tank is empty)/ 9,5 (bila tangki air kosong)							
Water tank volume (L)/ Volume tangki air (L)	Approx. 2.7/ Sekitar 2,7							
Power supply cord length (m)/ Panjang kabel catu daya (m)	1.8/ 1,8							

- These specification values are applicable to both 50Hz 220–240V and 60Hz 220–230V.

Nilai spesifikasi ini berlaku untuk 50 Hz 220–240 V dan 60 Hz 220–230 V.

- Even when the power is off, approx. 1W of power is consumed to run the microcomputer.
Bahkan saat listrik mati, sekitar 1 W daya digunakan untuk menjalankan komputer mikro.

*1. When there is water in the water tank, the water level may fall and ambient humidity may rise slightly.

Bila ada air dalam tangki air, tinggi air mungkin akan turun dan kelembapan mungkin akan naik sedikit.

*2. Humidifying rate was calculated in accordance with JEM1426. (when FAN setting is "Turbo")

Laju pelembapan dihitung sesuai dengan JEM1426. (bila pengaturan KIPAS adalah "Turbo")

*3. Coverage area was calculated in accordance with JEM1467. (when FAN setting is "Turbo")

Luas jangkauan dihitung sesuai dengan JEM1467. (bila pengaturan KIPAS adalah "Turbo")

*4. Coverage area was calculated in accordance with JEM1426. (when FAN setting is "Turbo")

Luas jangkauan dihitung sesuai dengan JEM1426. (bila pengaturan KIPAS adalah "Turbo")

Humidifying rate

(at indoor temp.: 20°C, indoor humidity: 30%)/

Laju pelembapan

(pada suhu dalam-ruang: 20 °C, kelembapan dalam-ruang: 30 %)

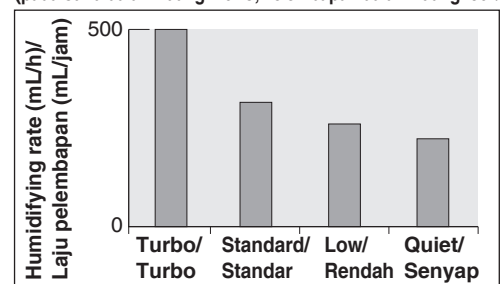

DAIKIN INDUSTRIES, LTD.

Head office:

Umeda Center Bldg., 2-4-12, Nakazaki-Nishi,
Kita-ku, Osaka, 530-8323 Japan

Tokyo office:

JR Shinagawa East Bldg., 2-18-1, Konan,
Minato-ku, Tokyo, 108-0075 Japan
<http://www.daikin.com>

The bar code is a manufacturing code.



The two-dimensional bar code is
a manufacturing code.

3P440431-1E M15B239E (1803)HT